

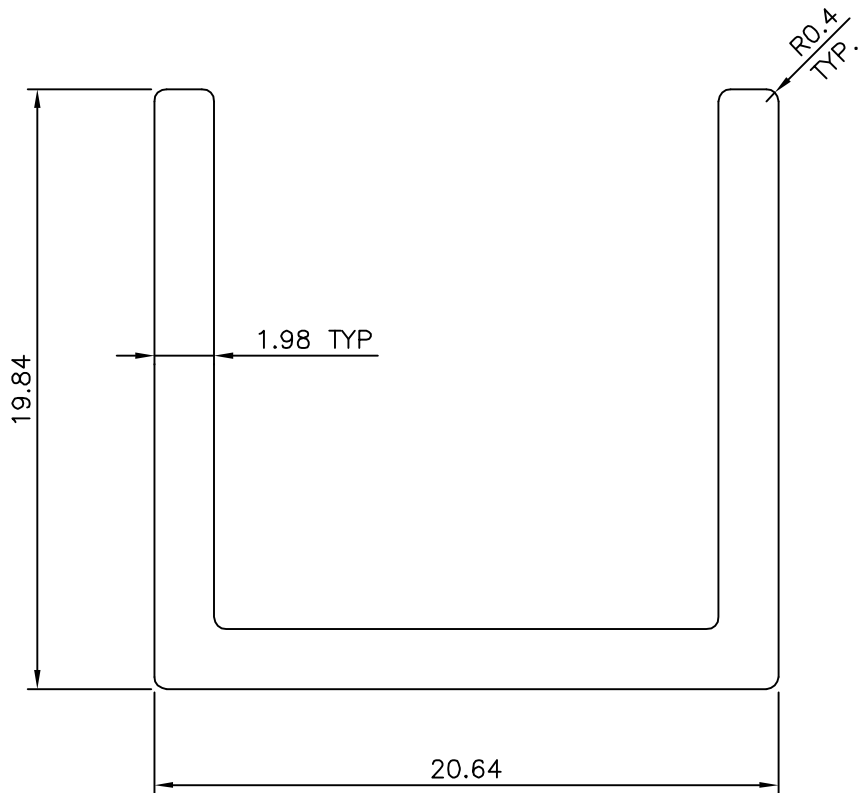

P-5967
S1730
15735
E0971

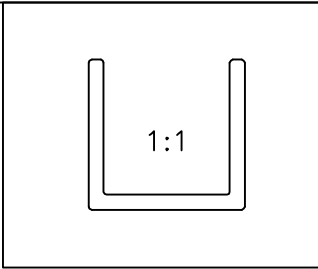

GENERAL WALL THICKNESS :- 1.98 mm.

 SYMBOL OF QUALITY AN ISO 9001 COMPANY	<b>JINDAL ALUMINIUM LTD.</b> BANGALORE-560073 (INDIA)	NAME		DATE
		DRAWN	MAHALINGAPPA	16-11-2005
1. ALL DIMENSIONS ARE IN mm. 2. ROUND OFF ALL SHARP CORNERS WITH 0.40 mm. 3. TOLERANCES WILL BE AS PER IS:3965-1981 UNLESS OTHERWISE SPECIFIED		CHECKED		
		APPROVED		
PARTY'S NAME HAFELE INDIA PVT. LTD., MUMBAI		SCALE		4:1
		AREA mm <sup>2</sup>		111.455
PARTY'S DRAWING No. 94A		PERIMETER mm.		115.307
		WEIGHT kg/m		0.301
ALLOY & TEMPER 6061 T6		DRAWING No.		SECTION No.
		P-5967		-
DESCRIPTION CHANNEL		S1730		S1730
		15735		15735
		E0971		E0971