

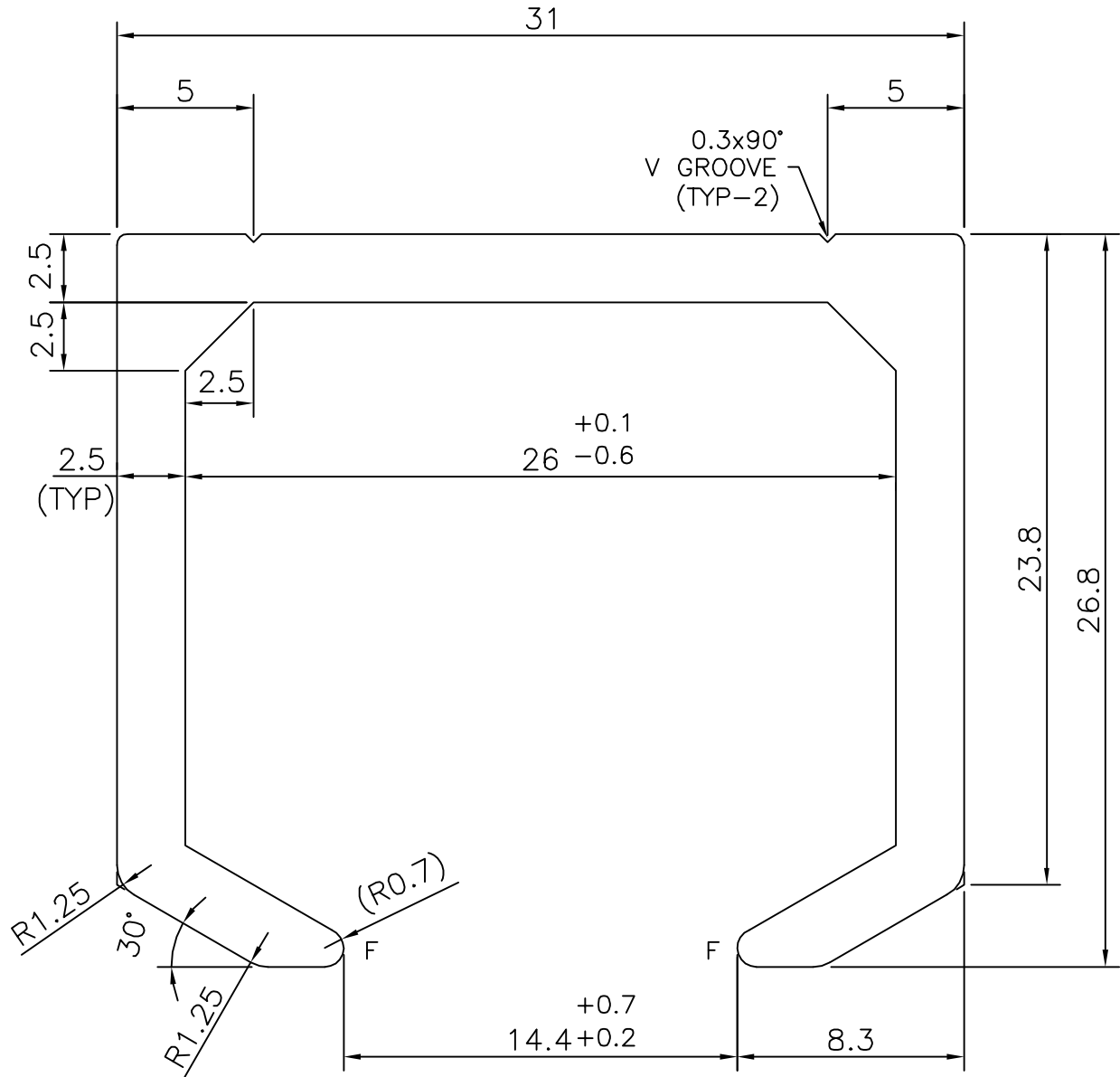

P-4252-2
X274
17615
E0972

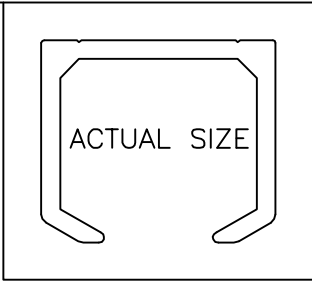

 SYMBOL OF QUALITY AN ISO 9002 COMPANY	<b>JINDAL ALUMINIUM LTD.</b> BANGALORE-560073 (INDIA)	NAME		DATE	
		DRAWN	SUDIP ROY	18.06.2003	
		CHECKED			
1. ALL DIMENSIONS ARE IN mm. 2. ROUND OFF ALL SHARP CORNERS WITH 0.40 mm. 3. TOLERANCES WILL BE AS PER IS 3965-1981 UNLESS OTHERWISE SPECIFIED		SCALE		1:1 / 4:1	
		AREA mm <sup>2</sup>		221	
		PERIMETER mm.		174.3	
PARTY'S NAME		HAFELE INDIA PVT. LTD., MUMBAI		WEIGHT kg/m	0.597
		PARTY'S DRAWING No.		AFD00010000	DRAWING No.
ALLOY & TEMPER		HE9 WP		P-4252-2	-
		DESCRIPTION		SLIDING DOOR TOP TRACK	X274
				17615	17615
				E0972	E0972