

P-JAL-B-338

E101515

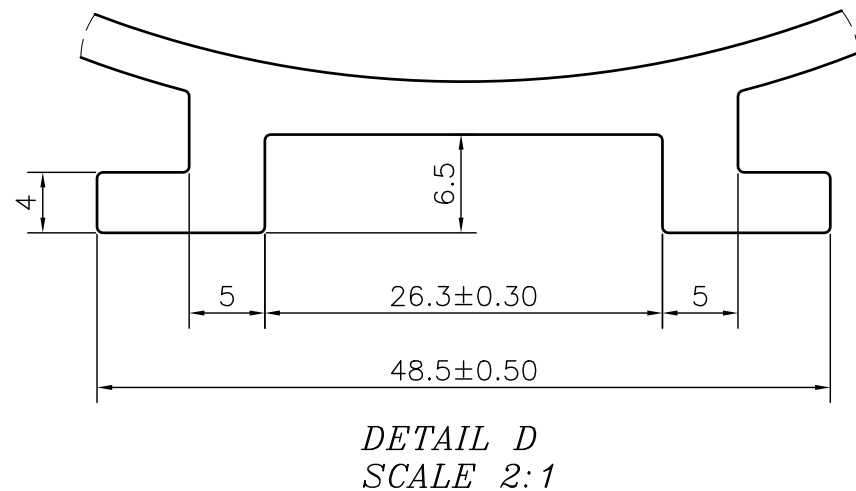
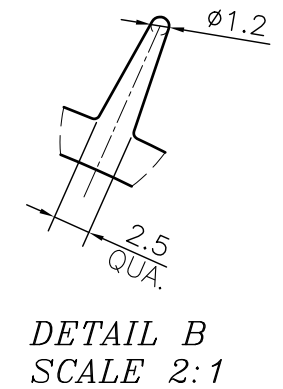
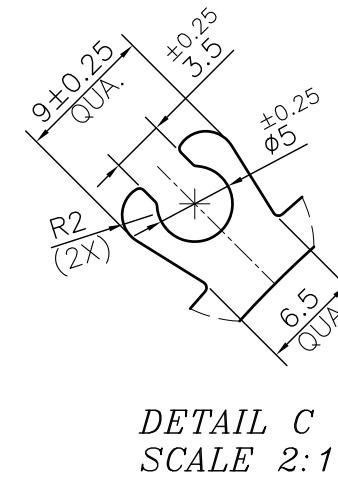
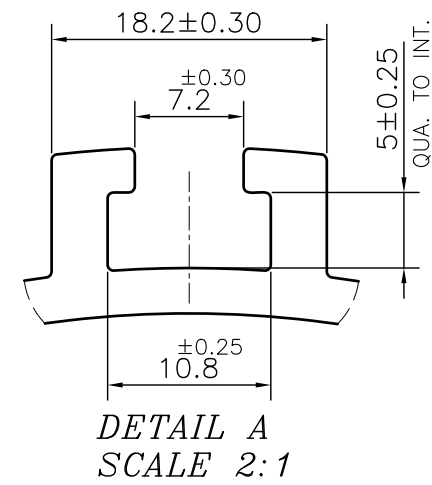
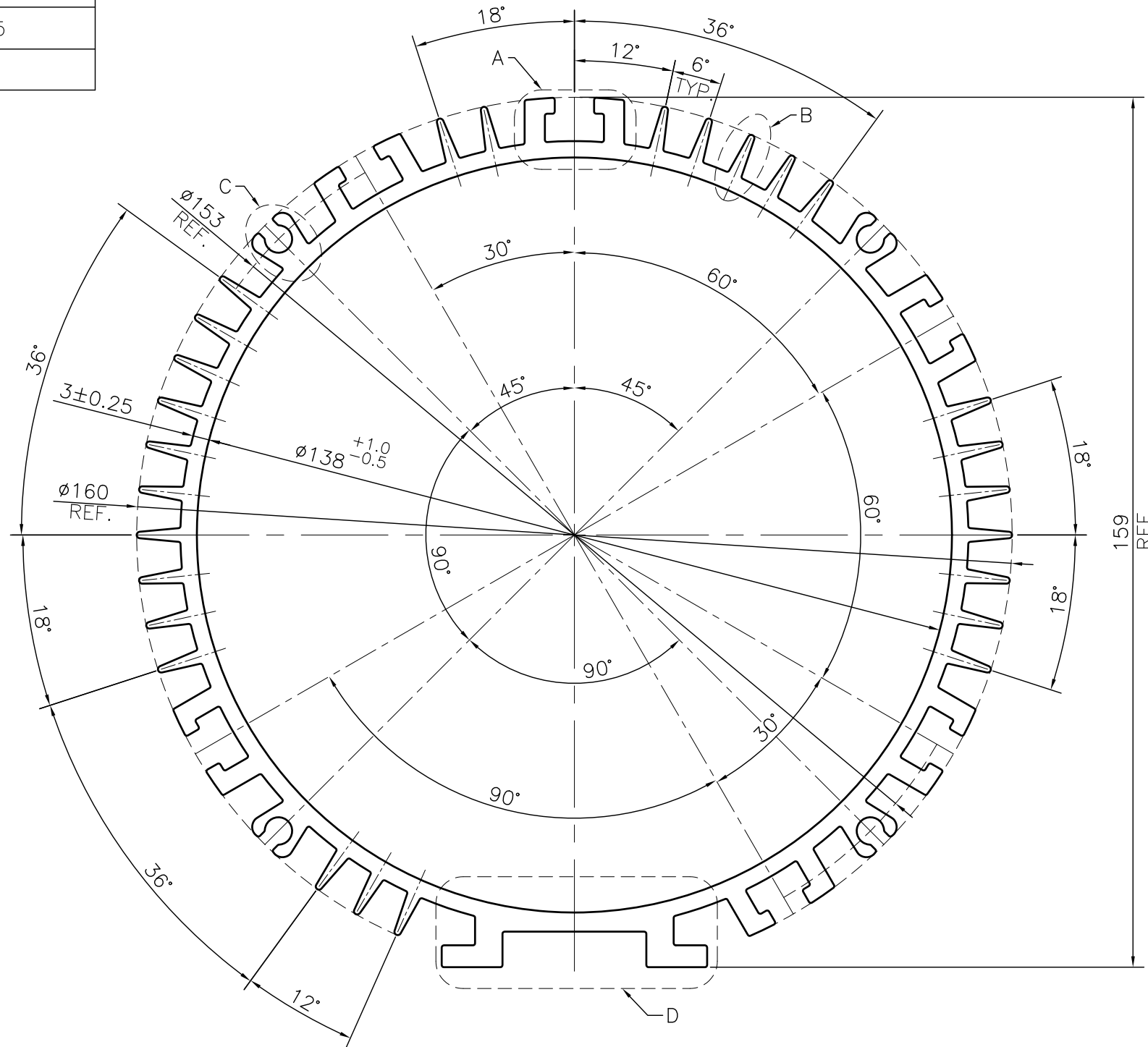

1. STRAIGHTNESS= 1.7mm/M
2. TWIST= 1.7mm/M
3. ANGULARITY= $\pm 2^\circ$
4. FLATNESS= 0.007xWIDTH

Q00892

CONTROLLED COPY



SYMBOL OF QUALITY
AN ISO 9001 COMPANY

JINDAL ALUMINIUM LTD.
BHIWADI-301019 (INDIA)

1. ALL DIMENSIONS ARE IN mm.
2. ROUND OFF ALL SHARP CORNERS WITH 0.40 mm.
3. TOLERANCES WILL BE AS PER BS:EN-755-9, UNLESS OTHERWISE SPECIFIED

PARTY'S NAME AVON MOTOR INDUSTRY, FARIDABAD

PARTY'S DRAWING No. AS PER MAIL 21.08.2023

ALLOY & TEMPER 6063 T6

DESCRIPTION MOTOR BODY SECTION

PRODUCT CODE:-084
HSN CODE:- 76042100

	NAME	DATE
DRAWN	ASHUTOSH	27-09-2023
CHECKED	PARVESH	18-10-2023
APPROVED	J.N. RAI	18-10-2023
SCALE		1:1
AREA	mm ²	2456.015
PERIMETER	mm.	1220.116
WEIGHT	kg/m	6.631
DRAWING No.	SECTION No.	
P-JAL-B-338	7000001661	
E101515	E101515	