

P-19289

E1050

EXPOSED SURFACE

1:1

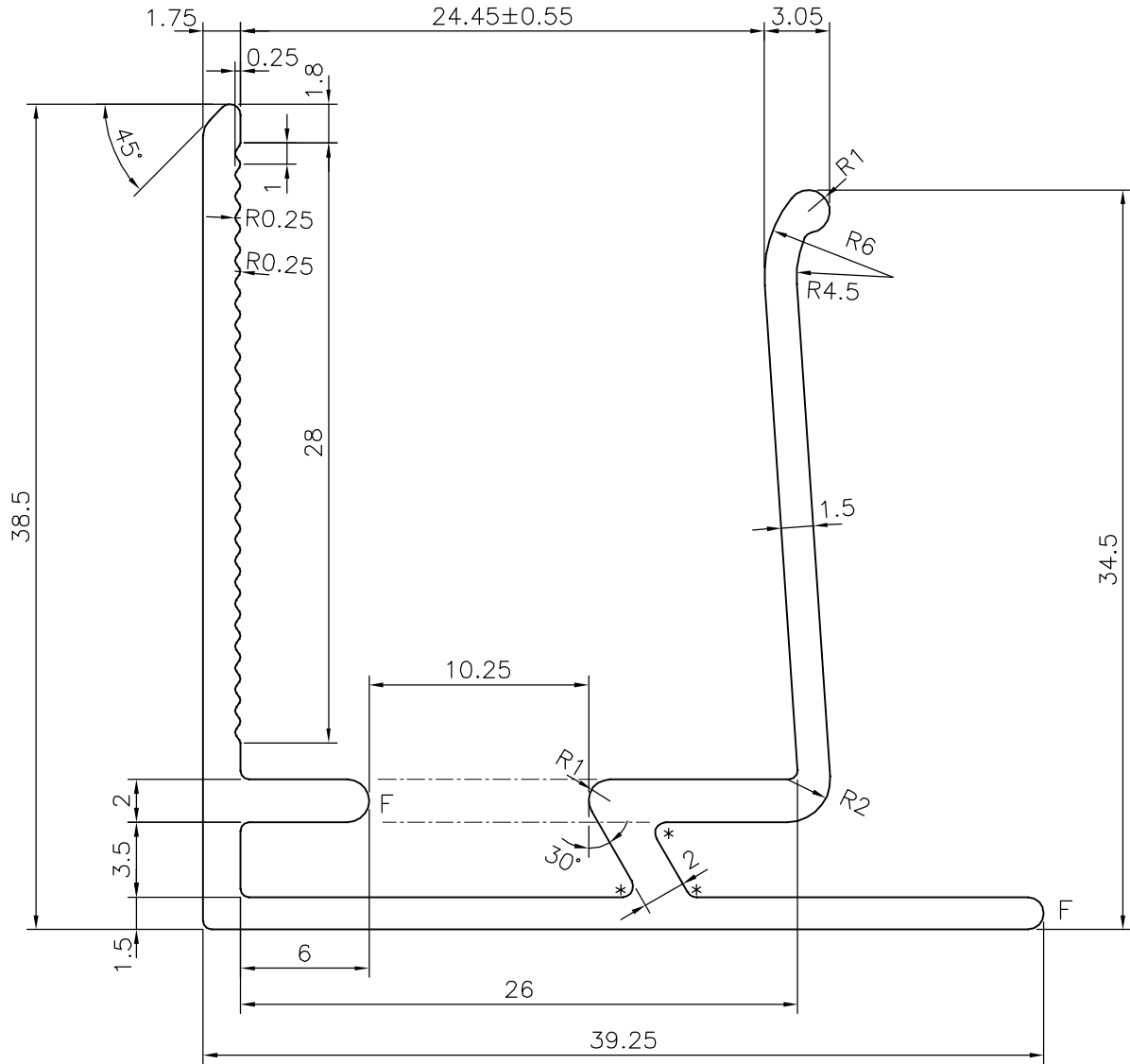

* = 0.5 RADIUS (3 PLACES)
 F = FULL RADIUS (2 PLACES)



SYMBOL OF QUALITY
 AN ISO 9001 COMPANY

JINDAL ALUMINIUM LTD.
 BANGALORE-560073 (INDIA)

	NAME	DATE
DRAWN	J.P.KAUSHIK	18-03-2019
CHECKED		
APPROVED	B.NATARAJA	02-04-2019
SCALE		3:1
AREA mm ²		202.991
PERIMETER mm.		250.862
WEIGHT kg/m		0.548
DRAWING No.	SECTION No.	
P-19289	-	
E1050	E1050	

1. ALL DIMENSIONS ARE IN mm.
2. ROUND OFF ALL SHARP CORNERS WITH 0.40 mm.
3. TOLERANCES WILL BE AS PER BS:EN-755-9 UNLESS OTHERWISE SPECIFIED

PARTY'S NAME CLEAR AMBER GROUP,UK

PARTY'S DRAWING No. 201962

ALLOY & TEMPER 6063 T6

DESCRIPTION MISC. SECTION