

P-19291

E1052

EXPOSED SURFACE

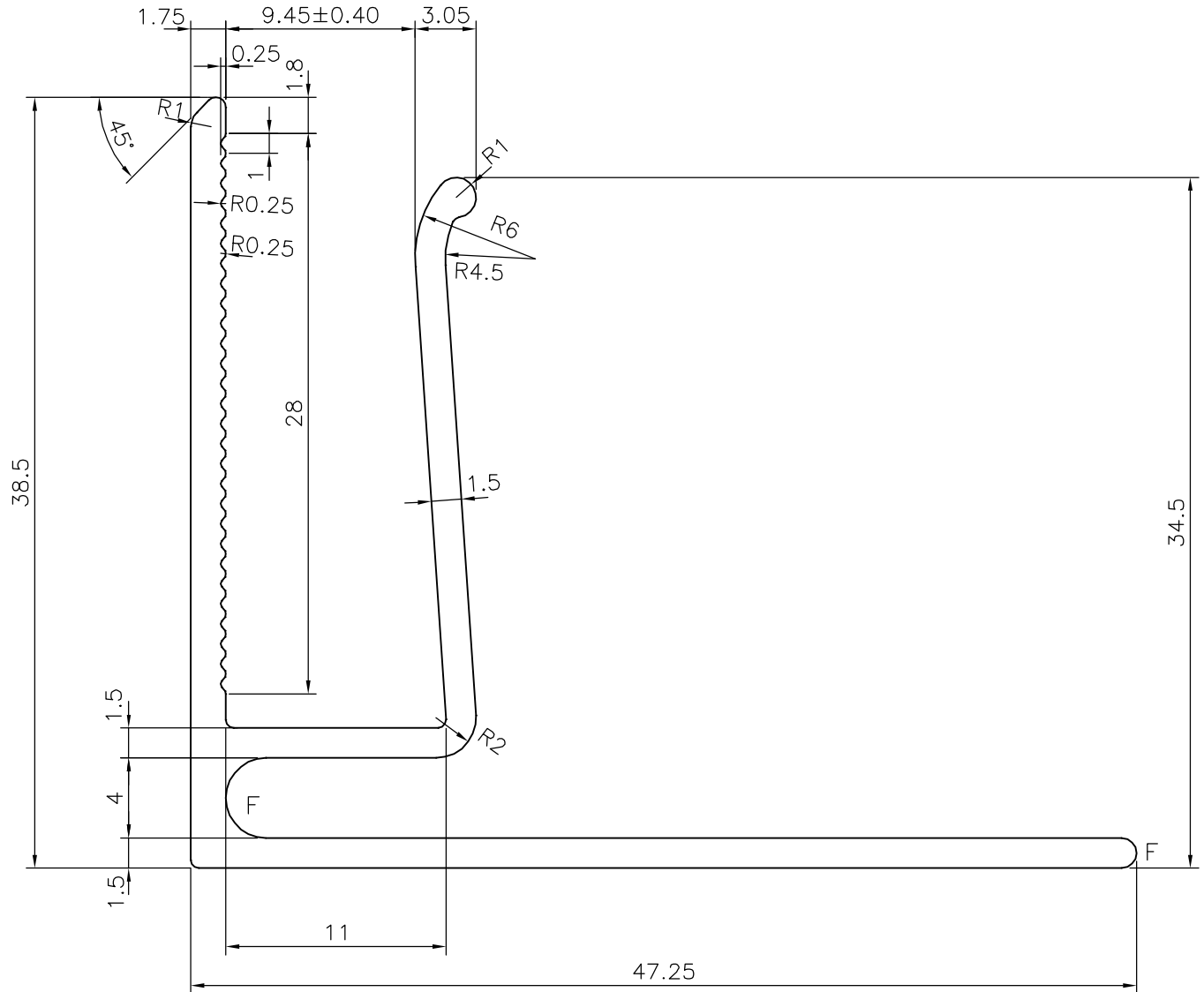
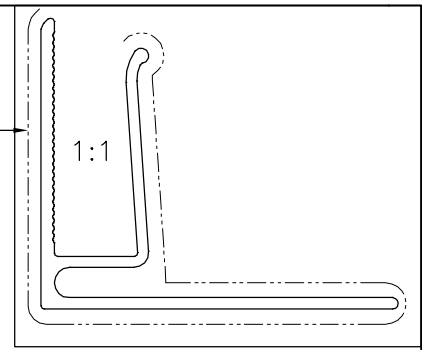

F = FULL RADIUS (2 PLACES)



SYMBOL OF QUALITY  
AN ISO 9001 COMPANY

**JINDAL ALUMINIUM LTD.**  
BANGALORE-560073 (INDIA)

	NAME	DATE
DRAWN	J.P.KAUSHIK	18-03-2019
CHECKED		
APPROVED	B.NATARAJA	02-04-2019
SCALE		3:1
AREA mm <sup>2</sup>		193.18
PERIMETER mm.		251.522
WEIGHT kg/m		0.522
DRAWING No.	SECTION No.	
P-19291	-	
E1052	E1052	

1. ALL DIMENSIONS ARE IN mm.
2. ROUND OFF ALL SHARP CORNERS WITH 0.40 mm.
3. TOLERANCES WILL BE AS PER BS:EN-755-9 UNLESS OTHERWISE SPECIFIED

PARTY'S NAME	CLEAR AMBER GROUP,UK
PARTY'S DRAWING No.	203385
ALLOY & TEMPER	6063 T6
DESCRIPTION	MISC. SECTION