

P-19295

E1056

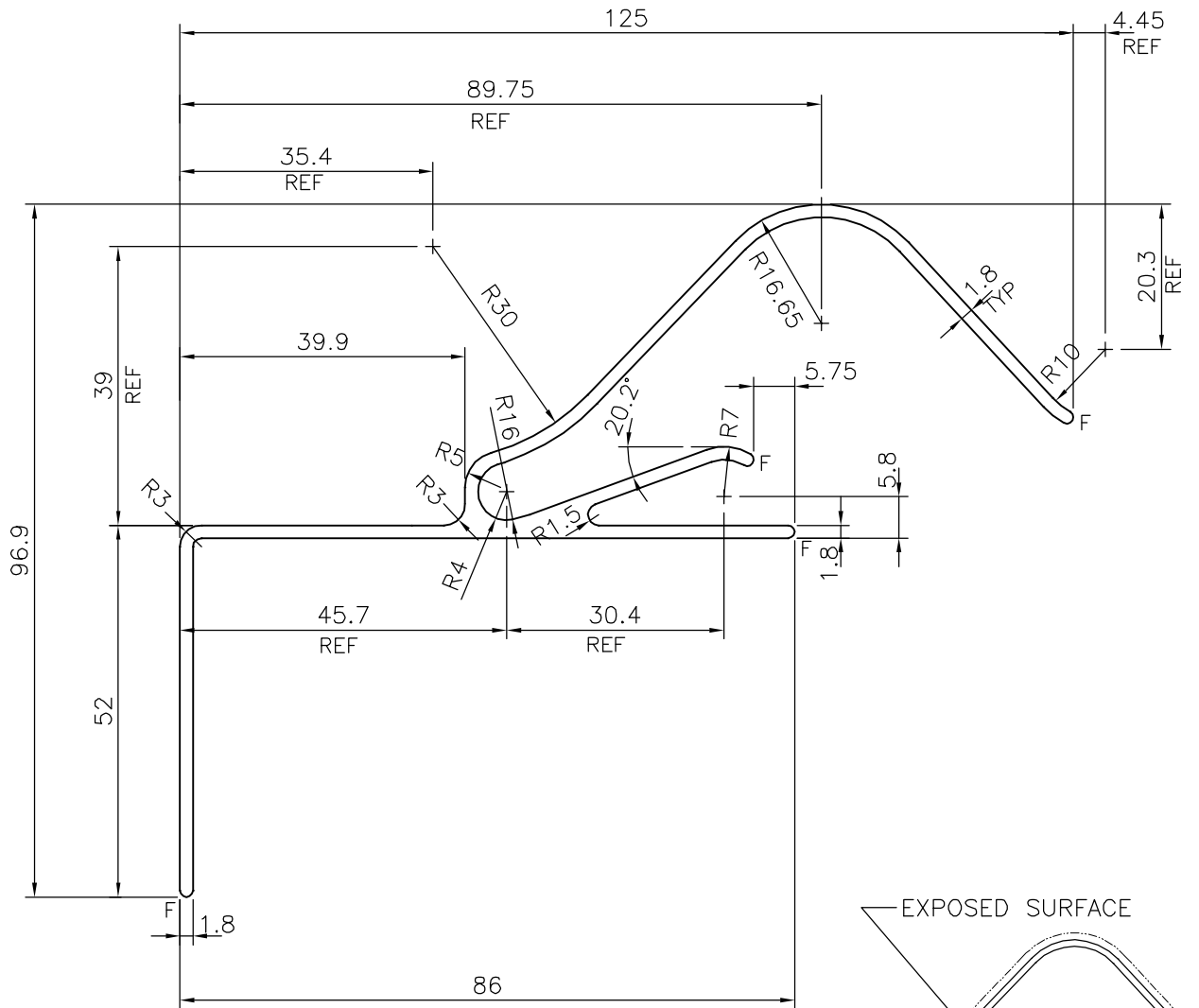

SCALE:-1:2

F = FULL RADIUS (4 PLACES)



SYMBOL OF QUALITY  
AN ISO 9001 COMPANY

**JINDAL ALUMINIUM LTD.**  
BANGALORE-560073 (INDIA)

	NAME	DATE
DRAWN	J.P.KAUSHIK	18-03-2019
CHECKED		
APPROVED	B.NATARAJA	02-04-2019
SCALE		1:1
AREA mm <sup>2</sup>		532.874
PERIMETER mm.		553.321
WEIGHT kg/m		1.439
DRAWING No.	SECTION No.	
P-19295	-	
E1056	E1056	

1. ALL DIMENSIONS ARE IN mm.
2. ROUND OFF ALL SHARP CORNERS WITH 0.40 mm.
3. TOLERANCES WILL BE AS PER BS:EN-755-9 UNLESS OTHERWISE SPECIFIED

PARTY'S NAME	CLEAR AMBER GROUP,UK
PARTY'S DRAWING No.	AS PER DRAWING
ALLOY & TEMPER	6063 T6
DESCRIPTION	MISC. SECTION