

P-19315

E1060

EXPOSED SURFACE

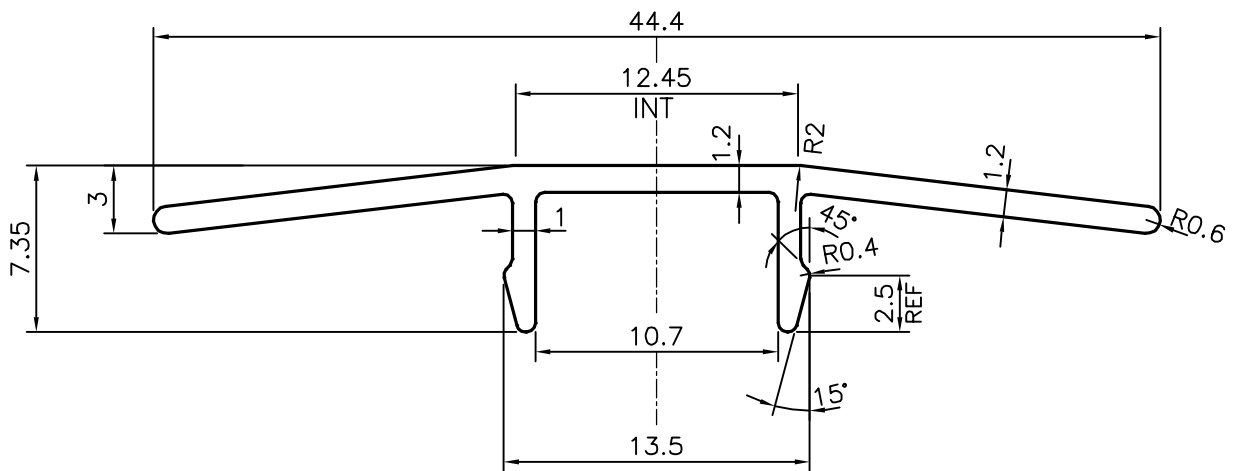
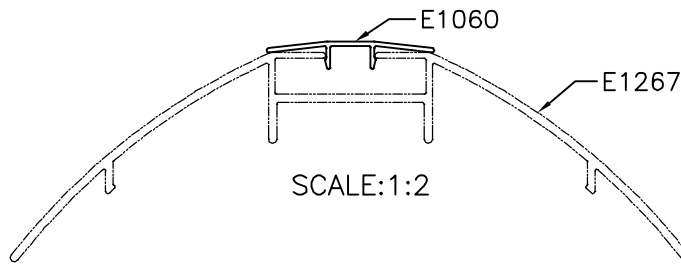
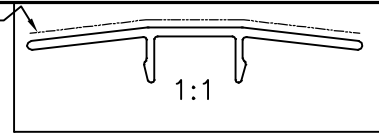

SYMBOL OF QUALITY
AN ISO 9001 COMPANY

JINDAL ALUMINIUM LTD.
BANGALORE-560073 (INDIA)

	NAME	DATE
DRAWN	J.P.KAUSHIK	23-03-2019
CHECKED		
APPROVED	B.NATARAJA	02-04-2019
SCALE		3:1
AREA mm ²		66.258
PERIMETER mm.		113.747
WEIGHT kg/m		0.179
DRAWING No.	SECTION No.	
P-19315	-	
E1060	E1060	

1. ALL DIMENSIONS ARE IN mm.
2. ROUND OFF ALL SHARP CORNERS WITH 0.40 mm.
3. TOLERANCES WILL BE AS PER BS:EN-755-9 UNLESS OTHERWISE SPECIFIED

PARTY'S NAME	CLEAR AMBER GROUP, UK
PARTY'S DRAWING No.	CA EXTRUSION 039 REV. V1.01
ALLOY & TEMPER	6063 T6
DESCRIPTION	CLIP SECTION