

P-19363

E1061

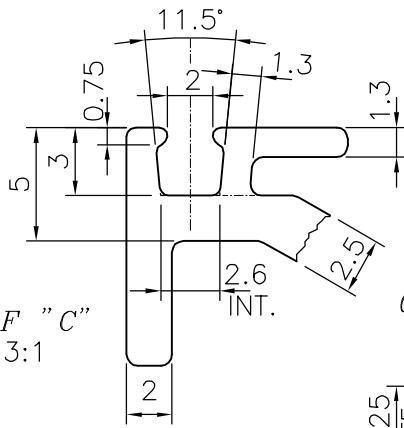

DETAIL OF "C"
SCALE 3:1

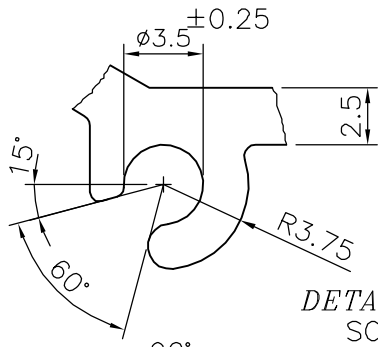

DETAIL OF "B"
SCALE 3:1

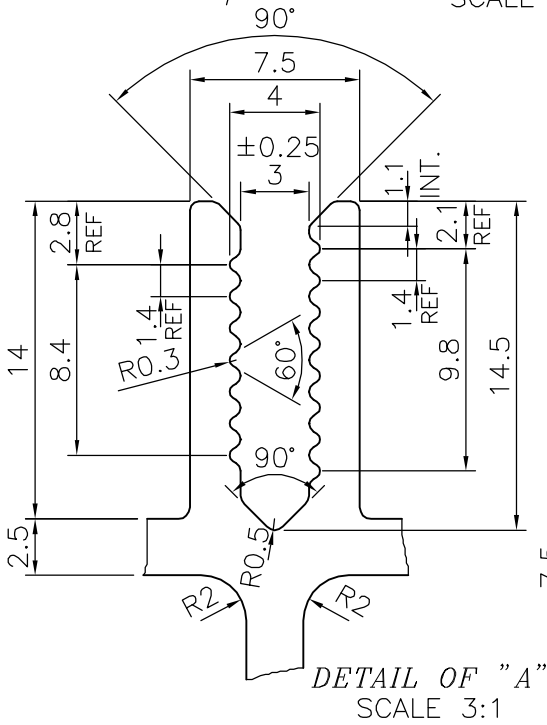

DETAIL OF "A"
SCALE 3:1

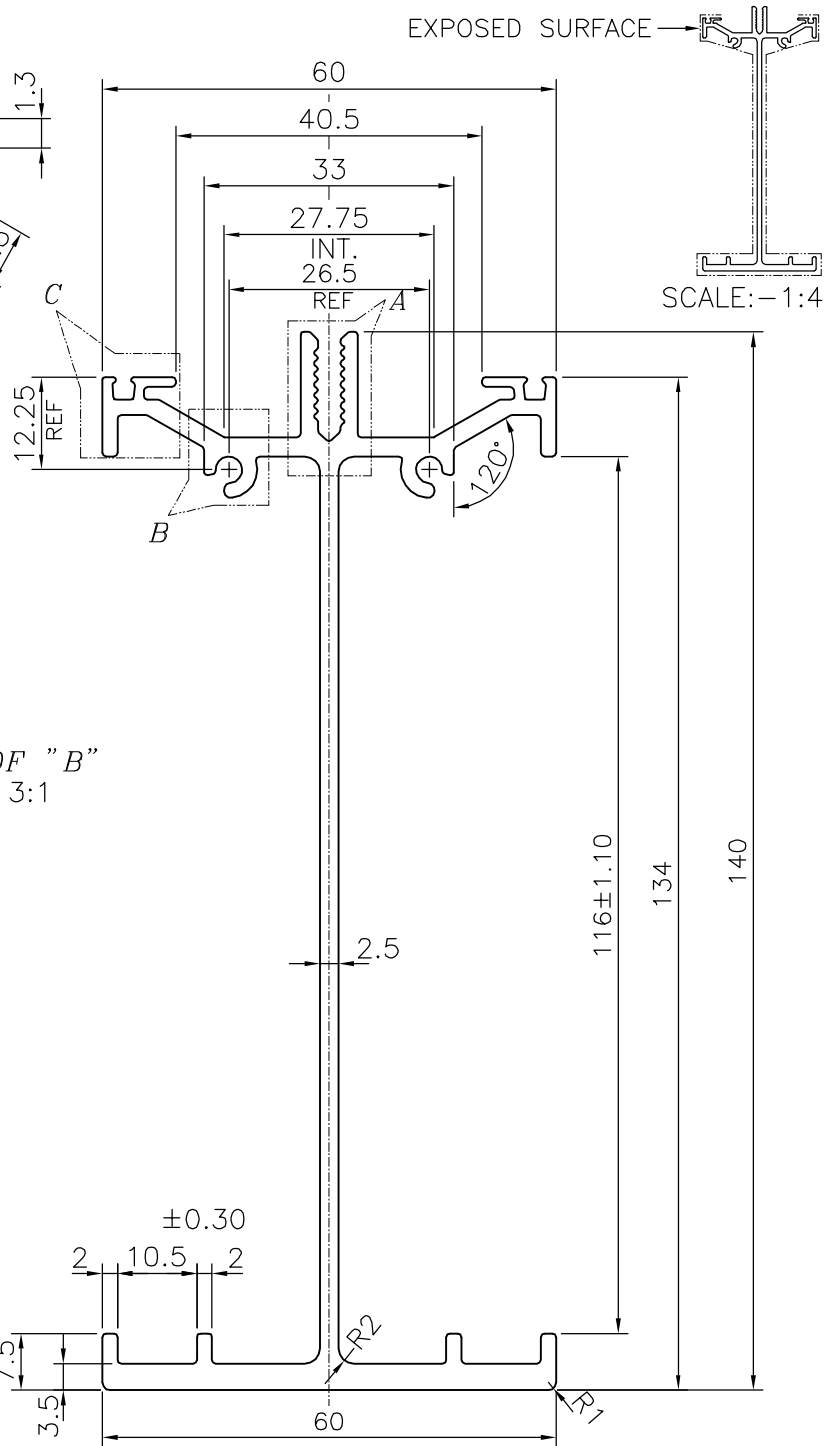

UNSPECIFIED RADIUS 0.5 mm



SYMBOL OF QUALITY
AN ISO 9001 COMPANY

JINDAL ALUMINIUM LTD.
BANGALORE-560073 (INDIA)

	NAME	DATE
DRAWN	J.P.KAUSHIK	28-03-2019
CHECKED		
APPROVED	B.NATARAJA	02-04-2019

1. ALL DIMENSIONS ARE IN mm.
2. ROUND OFF ALL SHARP CORNERS WITH 0.40 mm.
3. TOLERANCES WILL BE AS PER BS:EN-755-9 UNLESS OTHERWISE SPECIFIED

SCALE	1:1
AREA mm ²	840.396
PERIMETER mm.	669.385
WEIGHT kg/m	2.269
DRAWING No.	SECTION No.
P-19363	-
E1061	E1061

PARTY'S NAME	CLEAR AMBER GROUP, UK
PARTY'S DRAWING No.	209903
ALLOY & TEMPER	6063 T6
DESCRIPTION	MISC. SECTION