

P-19185-2

E1076

EXPOSED SURFACE

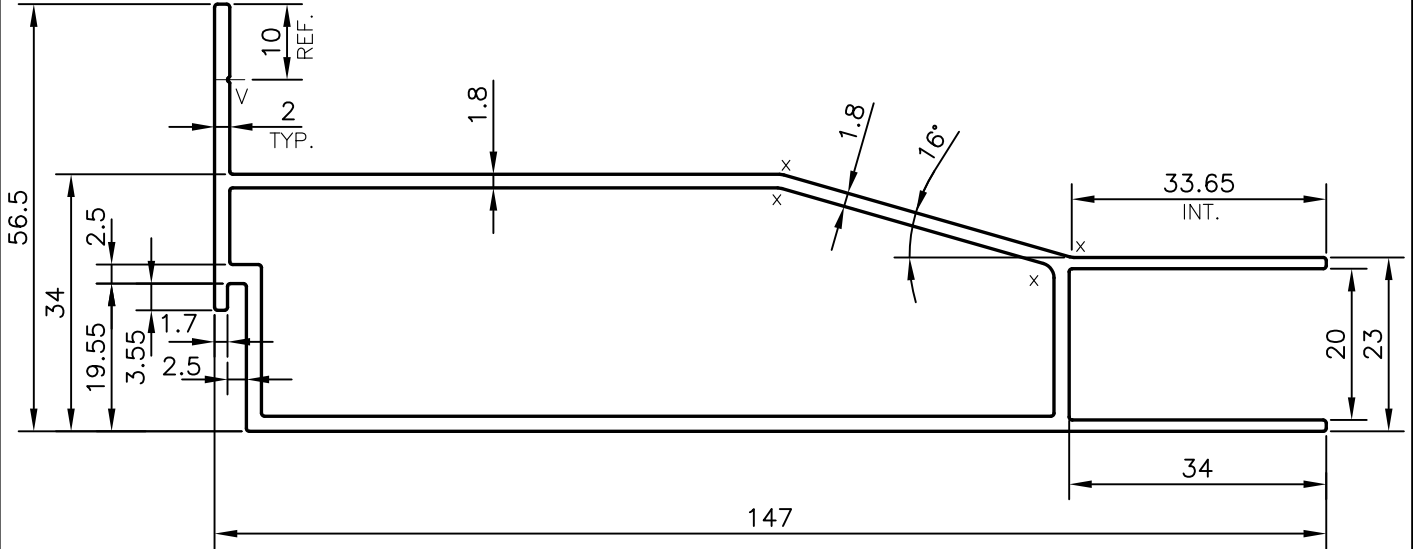
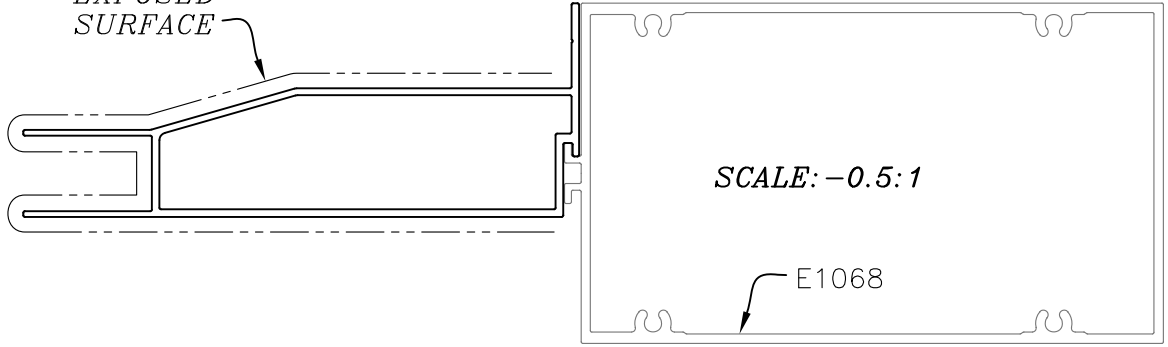

X = RADIUS 2 mm. (4 PLACES)  
 V = VEE GROOVE 0.3x90° (1 PLACE)

TOLERANCES ON OVERALL WIDTHS & WIDTHS ACROSS FLATS OF BARS, & REGULAR SECTIONS

UPTO 6.40mm - ±0.20	UPTO 32.0mm - ±0.38	UPTO 120.0mm - ±0.85	<b>1. STRAIGHTNESS=1.0mm/M</b> <b>2. TWIST=1.0mm/M</b> <b>3. ANGULARITY= ±1°</b> <b>4. FLATNESS =0.007xWIDTH</b>
UPTO 10.0mm - ±0.23	UPTO 50.0mm - ±0.46	UPTO 160.0mm - ±1.02	
UPTO 12.0mm - ±0.25	UPTO 60.0mm - ±0.53	UPTO 200.0mm - ±1.14	
UPTO 16.0mm - ±0.28	UPTO 80.0mm - ±0.69	UPTO 250.0mm - ±1.40	
UPTO 25.0mm - ±0.30	UPTO 100.0mm - ±0.75	UPTO 300.0mm - ±1.65	

PLEASE CONFIRM ALL THE DIMENSIONS AND MATCH WITH YOUR MATCHING COMPONENT

PLEASE SPECIFY THE EXPOSED SURFACE IN THE DRAWING WHEREVER BETTER FINISH REQUIRED.

 SYMBOL OF QUALITY AN ISO 9001 COMPANY	<b>JINDAL ALUMINIUM LTD.</b> BANGALORE-560073 (INDIA)	NAME	DATE
		DRAWN	PARVESH 01-03-2019
		CHECKED	
		APPROVED	B.NATARAJA 11-04-2019
1. ALL DIMENSIONS ARE IN mm. 2. ROUND OFF ALL SHARP CORNERS WITH 0.4 mm. 3. TOLERANCES WILL BE AS PER IS:6477-1983 , UNLESS OTHERWISE SPECIFIED		SCALE	1:1
		AREA mm <sup>2</sup>	686.988
		PERIMETER mm.	470.458
		WEIGHT kg/m	1.855
		DRAWING No.	SECTION No.
PARTY'S NAME	ALUFIT (INDIA) PRIVATE LIMITED, BANGALORE	P-19185-2	-
PARTY'S DRAWING No.	AS PER AUTOCAD DRAWING-4SR-DIE-22	E1076	E1076
ALLOY & TEMPER	6063 T6		
DESCRIPTION	CURTAIN WALL SECTION-EDGE GUARD ADAPTER		