

P-19200

E1086

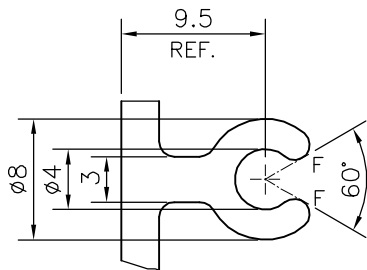
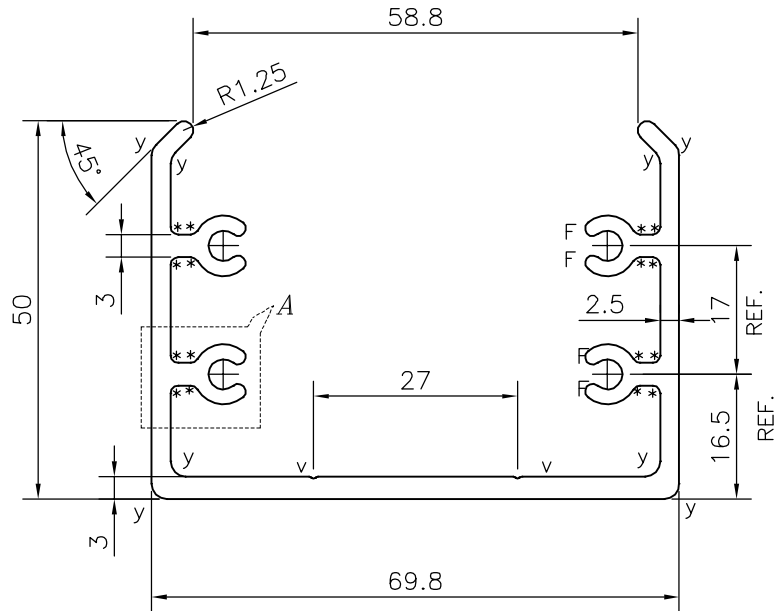

DETAIL OF "A"
SCALE 2:1

- * = 1.0 RADIUS (16 PLACES)
- V = VEE GROOVE 0.3x90° (2 PLACES)
- y = RADIUS 2 mm. (8 PLACES)
- F = FULL RADIUS (8 PLACES)

TOLERANCES ON OVERALL WIDTHS & WIDTHS ACROSS FLATS OF BARS, & REGULAR SECTIONS

UPTO 6.40mm - ±0.20	UPTO 32.0mm - ±0.38	UPTO 120.0mm - ±0.85	1. STRAIGHTNESS=1.0mm/M 2. TWIST=1.0mm/M 3. ANGULARITY= ±1° 4. FLATNESS =0.007xWIDTH
UPTO 10.0mm - ±0.23	UPTO 50.0mm - ±0.46	UPTO 160.0mm - ±1.02	
UPTO 12.0mm - ±0.25	UPTO 60.0mm - ±0.53	UPTO 200.0mm - ±1.14	
UPTO 16.0mm - ±0.28	UPTO 80.0mm - ±0.69	UPTO 250.0mm - ±1.40	
UPTO 25.0mm - ±0.30	UPTO 100.0mm - ±0.75	UPTO 300.0mm - ±1.65	

 SYMBOL OF QUALITY AN ISO 9001 COMPANY	JINDAL ALUMINIUM LTD. BANGALORE-560073 (INDIA)	NAME	DATE
		DRAWN	J.P.KAUSHIK
		CHECKED	
		APPROVED	B.NATARAJA
			11-04-2019
1. ALL DIMENSIONS ARE IN mm. 2. ROUND OFF ALL SHARP CORNERS WITH 0.40 mm. 3. TOLERANCES WILL BE AS PER IS:3965-1981 , UNLESS OTHERWISE SPECIFIED		SCALE	1:1
		AREA mm ²	610.212
		PERIMETER mm.	465.055
		WEIGHT kg/m	1.648
PARTY'S NAME	ALUFIT (INDIA) PRIVATE LIMITED, BANGALORE	DRAWING No.	SECTION No.
PARTY'S DRAWING No.	4SR-DIE-19	P-19200	-
ALLOY & TEMPER	6063 T6	E1086	E1086
DESCRIPTION	TRANSOM CONNECTOR		