

P-19469

E1116

EXPOSED SURFACE

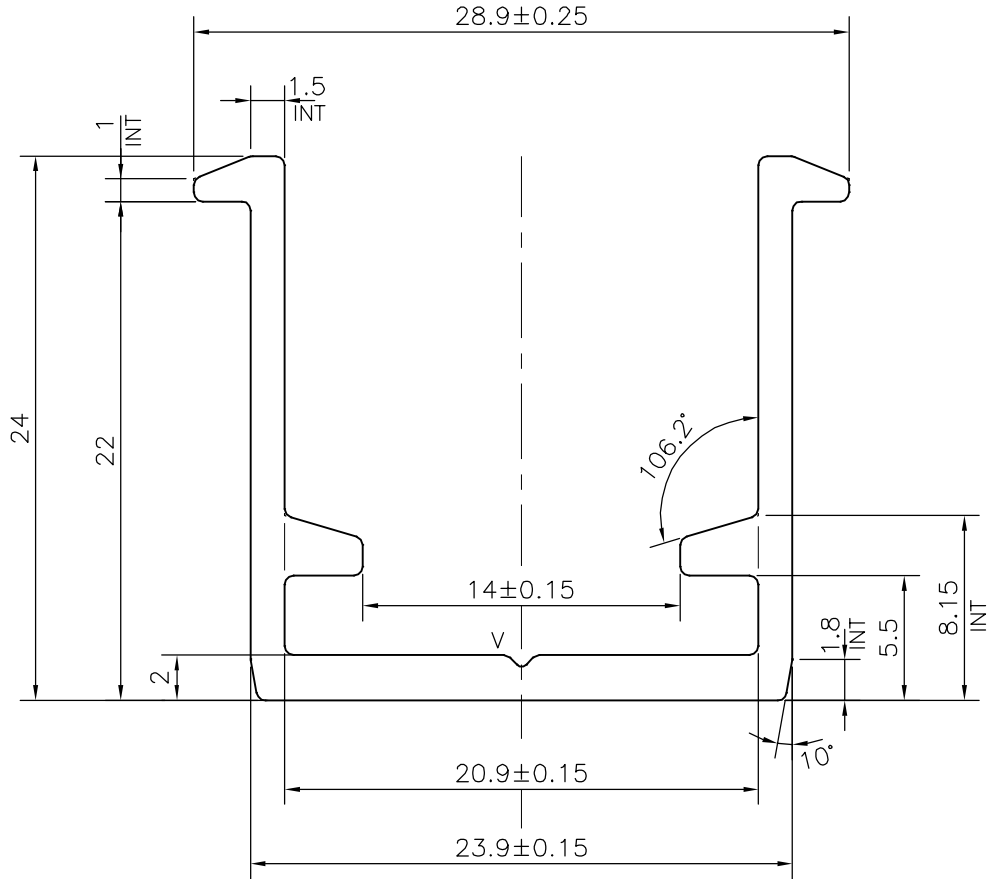
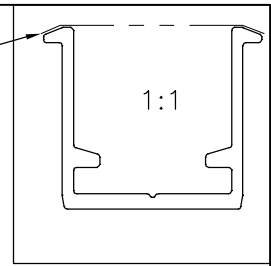

V = V GROOVE 0.5x90° (1 PLACE)



SYMBOL OF QUALITY
AN ISO 9001 COMPANY

JINDAL ALUMINIUM LTD.
BANGALORE-560073 (INDIA)

	NAME	DATE
DRAWN	J.P.KAUSHIK	25-04-2019
CHECKED		
APPROVED	B.NATARAJA	20-05-2019

1. ALL DIMENSIONS ARE IN mm.
2. ROUND OFF ALL SHARP CORNERS WITH 0.40 mm.
3. TOLERANCES WILL BE AS PER IS:3965-1981 , UNLESS OTHERWISE SPECIFIED

SCALE	3:1
AREA mm ²	135.106
PERIMETER mm.	157.278
WEIGHT kg/m	0.365

PARTY'S NAME	HAFELE INDIA PVT. LTD., MUMBAI	DRAWING No.	P-19469	SECTION No.	-
PARTY'S DRAWING No.	04-150417-FZ-1401		E1116		E1116
ALLOY & TEMPER	6060 T6				
DESCRIPTION	MISC. SECTION				