

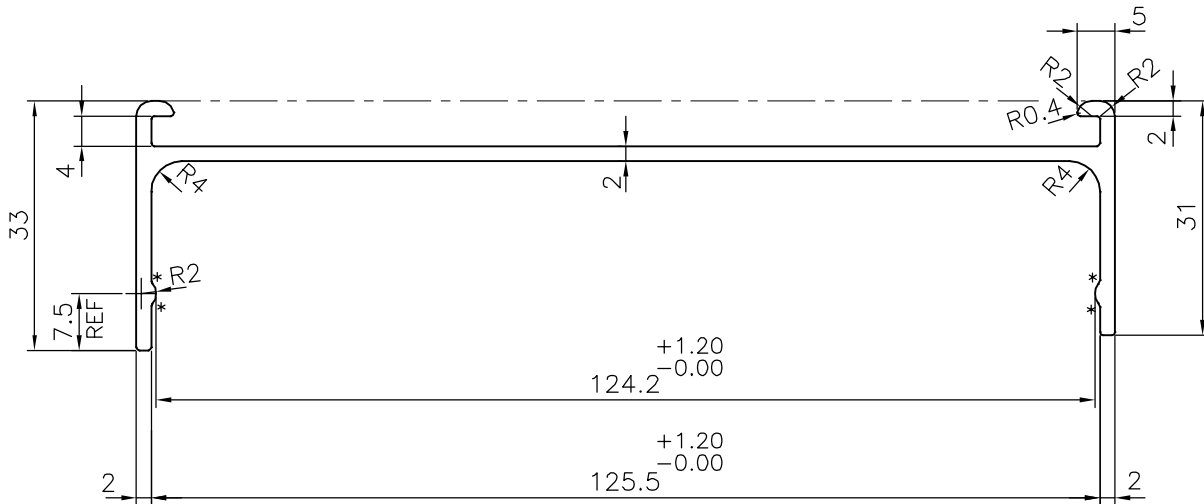

P-19570-3

E1117

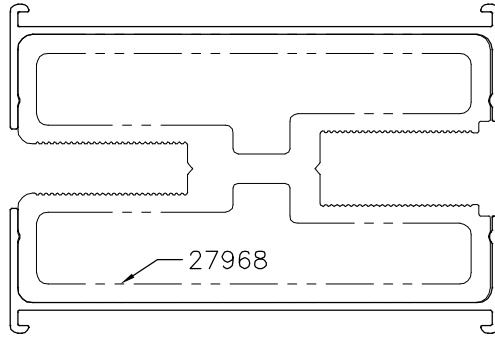

* = 0.8mm RADIUS (4 PLACES)

 SYMBOL OF QUALITY AN ISO 9001 COMPANY	JINDAL ALUMINIUM LTD. BANGALORE-560073 (INDIA)	NAME		DATE
		DRAWN	J.P.KAUSHIK	27-05-2019
1. ALL DIMENSIONS ARE IN mm. 2. ROUND OFF ALL SHARP CORNERS WITH 0.40 mm. 3. TOLERANCES WILL BE AS PER IS:3965-1981 UNLESS OTHERWISE SPECIFIED		CHECKED		
		APPROVED		B.NATARAJA 30-05-2019
PARTY'S NAME		SCALE		1:1
		AREA mm ²		397.221
PARTY'S DRAWING No.		PERIMETER mm.		387.148
		WEIGHT kg/m		1.072
ALLOY & TEMPER		DRAWING No.		SECTION No.
		P-19570-3		
DESCRIPTION		E1117		E1117
MRC-ATHENA TOP RAIL COVER				