

P-19462-1

E1118

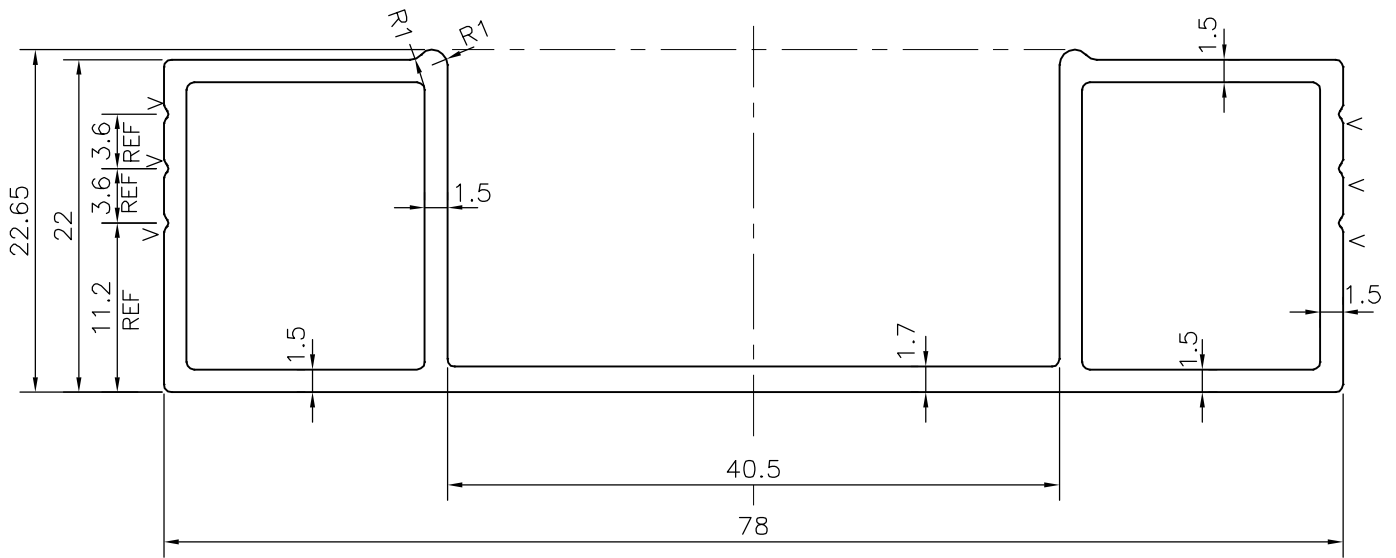

UNSPECIFIED RADIUS 0.5 mm
 V = V GROOVE 0.3x90° (6 PLACES)

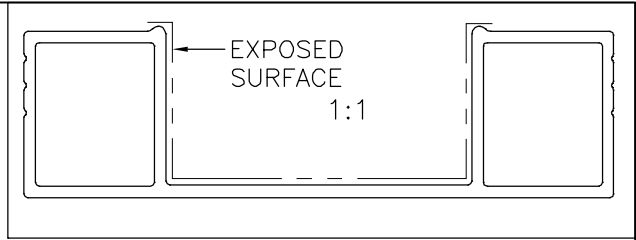

SYMBOL OF QUALITY
 AN ISO 9001 COMPANY

JINDAL ALUMINIUM LTD.
 BANGALORE-560073 (INDIA)

	NAME	DATE
DRAWN	J.P.KAUSHIK	14-05-2019
CHECKED		
APPROVED	B.NATARAJA	01-06-2019
SCALE		2:1
AREA mm ²		296.496
PERIMETER mm.		241.252
WEIGHT kg/m		0.801
DRAWING No.	SECTION No.	
P-19462-1	-	
E1118	E1118	

1. ALL DIMENSIONS ARE IN mm.
2. ROUND OFF ALL SHARP CORNERS WITH 0.40 mm.
3. TOLERANCES WILL BE AS PER IS:6477-1983 , UNLESS OTHERWISE SPECIFIED

PARTY'S NAME	KINGSPAN JINDAL PVT. LTD., GURGAON
PARTY'S DRAWING No.	211206 A
ALLOY & TEMPER	6063 T6
DESCRIPTION	PRECISION PANEL SECTION