

P-19531

E1122

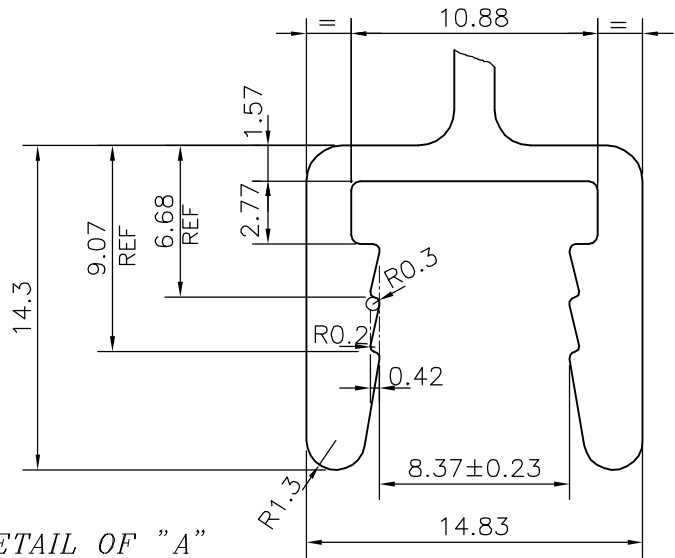

DETAIL OF "A"
SCALE 3:1

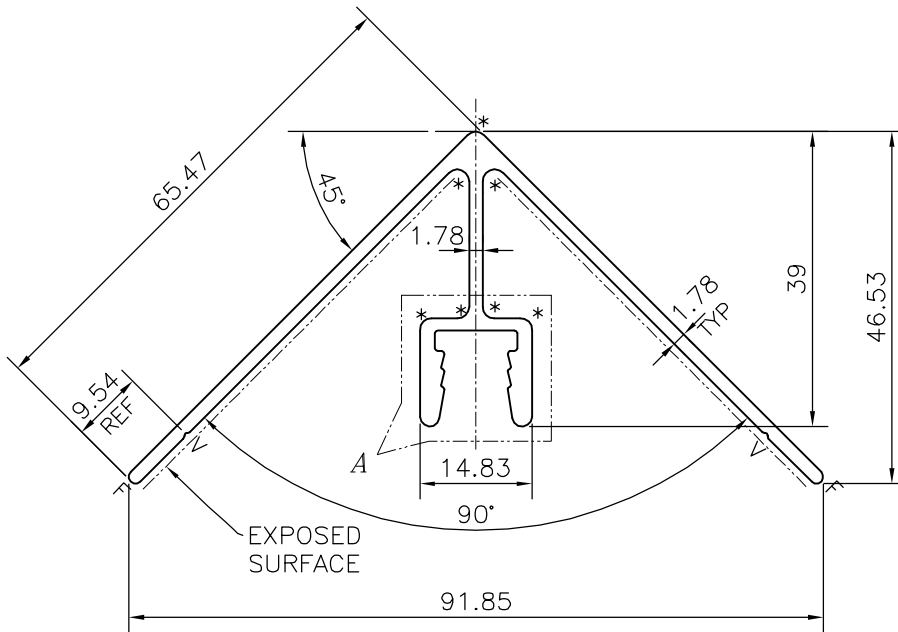

F = FULL RADIUS (2 PLACES)
 V = V GROOVE 0.3x90° (2 PLACES)
 * = 1.57 RADIUS (7 PLACES)



SYMBOL OF QUALITY
AN ISO 9001 COMPANY

JINDAL ALUMINIUM LTD.
BANGALORE-560073 (INDIA)

	NAME	DATE
DRAWN	J.P.KAUSHIK	09-05-2019
CHECKED		
APPROVED	B.NATARAJA	01-06-2019
SCALE		1:1
AREA mm ²		365.773
PERIMETER mm.		374.612
WEIGHT kg/m		0.988
DRAWING No.	SECTION No.	
P-19531	-	
E1122	E1122	

1. ALL DIMENSIONS ARE IN mm.
2. ROUND OFF ALL SHARP CORNERS WITH 0.40 mm.
3. TOLERANCES WILL BE AS PER IS:3965-1981, UNLESS OTHERWISE SPECIFIED

PARTY'S NAME	KINGSPAN JINDAL PVT. LTD., GURGAON
PARTY'S DRAWING No.	20620 REV.1
ALLOY & TEMPER	6063 T6
DESCRIPTION	MISC. SECTION