

P-19019-1

E1127

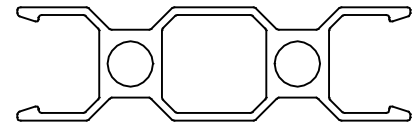

SCALE: - 1:1

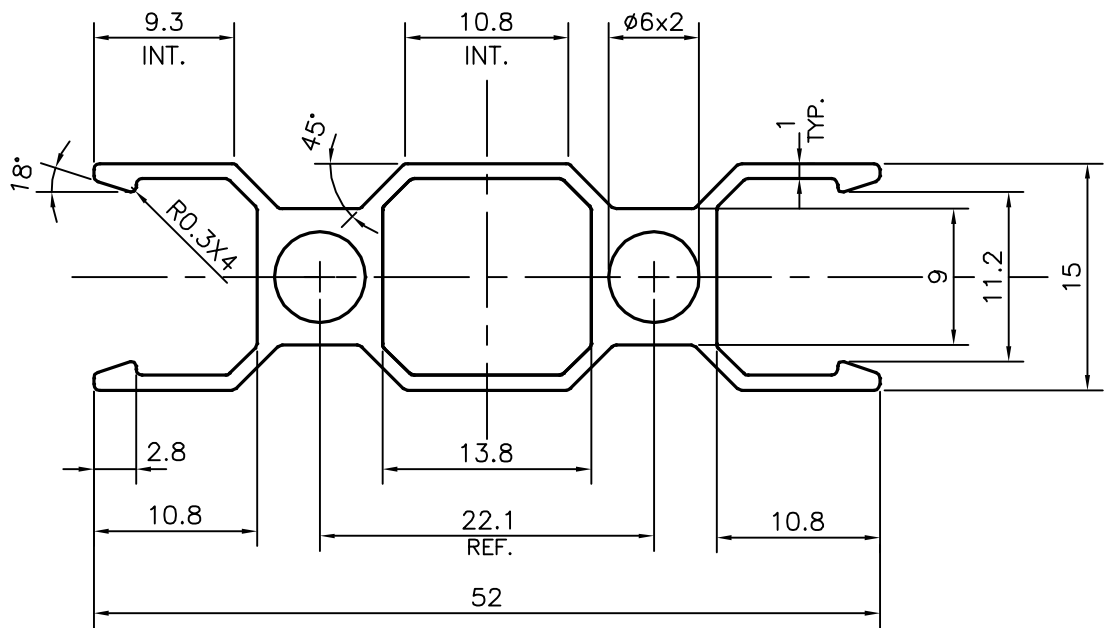
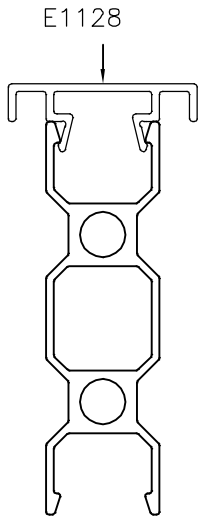

SCALE: - 1:1



SYMBOL OF QUALITY
AN ISO 9001 COMPANY

JINDAL ALUMINIUM LTD.
BANGALORE-560073 (INDIA)

	NAME	DATE
DRAWN	DARPAN	24-01-2019
CHECKED		
APPROVED	B.NATARAJA	07-06-2019
SCALE		2:1
AREA	mm ²	184.394
PERIMETER	mm.	184.554
WEIGHT	kg/m	0.498
DRAWING No.	SECTION No.	
P-19019-1	-	
E1127	E1127	

1. ALL DIMENSIONS ARE IN mm.
2. ROUND OFF ALL SHARP CORNERS WITH 0.40 mm.
3. TOLERANCES WILL BE AS PER IS:6477-1983 , UNLESS OTHERWISE SPECIFIED

PARTY'S NAME	ANIQ DESIGNS AND PRODUCTS, KERALA
PARTY'S DRAWING No.	AS PER AUTOCAD DRAWING
ALLOY & TEMPER	6063 T6
DESCRIPTION	MISC. SECTION