

P-19582-1

E1130

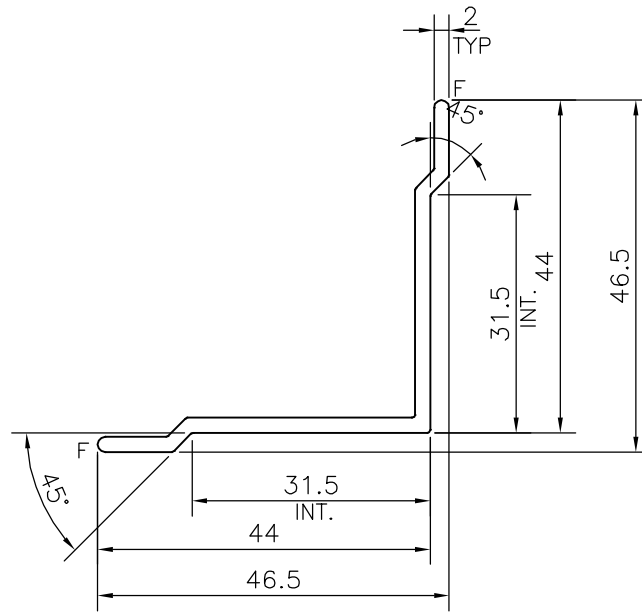

F = FULL RADIUS (2 PLACES)



SYMBOL OF QUALITY
AN ISO 9001 COMPANY

JINDAL ALUMINIUM LTD.
BANGALORE-560073 (INDIA)

	NAME	DATE
DRAWN	J.P.KAUSHIK	01-06-2019
CHECKED		
APPROVED	B.NATARAJA	14-06-2019
SCALE		1:1
AREA mm ²		175.284
PERIMETER mm.		177.944
WEIGHT kg/m		0.473
DRAWING No.	SECTION No.	
P-19582-1	-	
E1130	E1130	

1. ALL DIMENSIONS ARE IN mm.
2. ROUND OFF ALL SHARP CORNERS WITH 0.40 mm.
3. TOLERANCES WILL BE AS PER IS:3965-1981 , UNLESS OTHERWISE SPECIFIED

PARTY'S NAME	D.M. HEALTHCARE SOLUTIONS, BANGALORE
PARTY'S DRAWING No.	AS PER SAMPLE & REQUIREMENT
ALLOY & TEMPER	6063 T6
DESCRIPTION	EQUAL ANGLE-MISC.