

P-19583

E1131

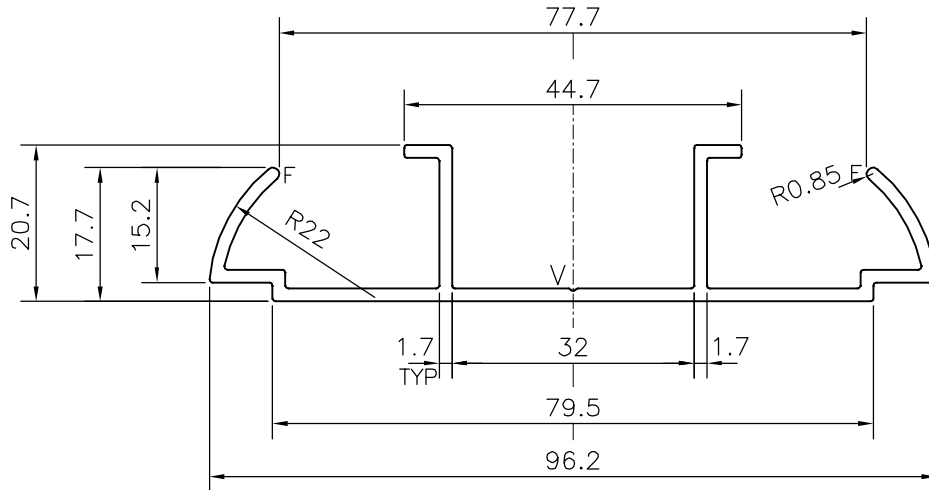

V = V GROOVE 0.3x90° (1 PLACE)  
 F = FULL RADIUS (2 PLACES)



SYMBOL OF QUALITY  
 AN ISO 9001 COMPANY

**JINDAL ALUMINIUM LTD.**  
 BANGALORE-560073 (INDIA)

	NAME	DATE
DRAWN	J.P.KAUSHIK	28-05-2019
CHECKED		
APPROVED	B.NATARAJA	14-06-2019
SCALE		1:1
AREA mm <sup>2</sup>		305.192
PERIMETER mm.		357.617
WEIGHT kg/m		0.824
DRAWING No.	SECTION No.	
P-19583	-	
E1131	E1131	

1. ALL DIMENSIONS ARE IN mm.
2. ROUND OFF ALL SHARP CORNERS WITH 0.40 mm.
3. TOLERANCES WILL BE AS PER IS:3965-1981 , UNLESS OTHERWISE SPECIFIED

PARTY'S NAME	D.M. HEALTHCARE SOLUTIONS, BANGALORE
PARTY'S DRAWING No.	AS PER SAMPLE
ALLOY & TEMPER	6063 T6
DESCRIPTION	MISC. SECTION