

P-19526

E1145

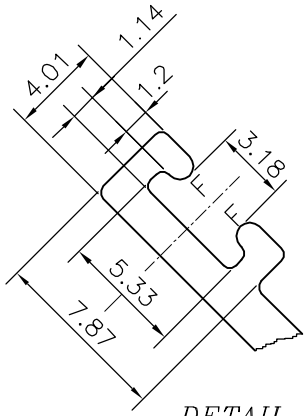

DETAIL OF "A"  
SCALE 3:1

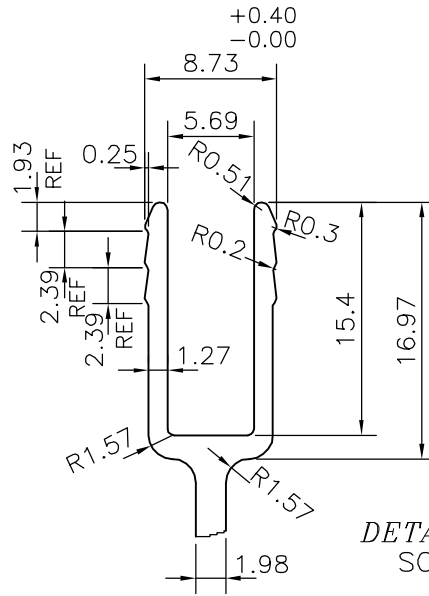

DETAIL OF "B"  
SCALE 2:1

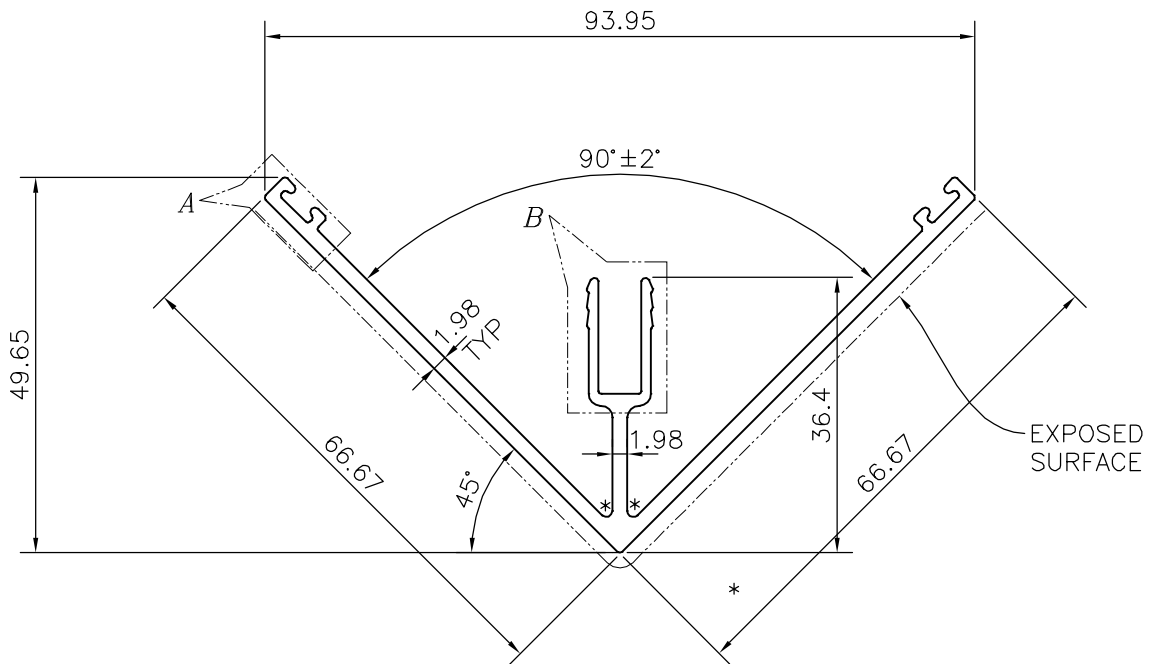

\* = 0.79 RADIUS (2 PLACES)  
F = FULL RADIUS (4 PLACES)



SYMBOL OF QUALITY  
AN ISO 9001 COMPANY

**JINDAL ALUMINIUM LTD.**  
BANGALORE-560073 (INDIA)

	NAME	DATE
DRAWN	J.P.KAUSHIK	08-05-2019
CHECKED		
APPROVED	B.NATARAJA	09-08-2019
SCALE		1:1
AREA mm <sup>2</sup>		358.609
PERIMETER mm.		388.308
WEIGHT kg/m		0.968
DRAWING No.	SECTION No.	
P-19526	-	
E1145	E1145	

1. ALL DIMENSIONS ARE IN mm.
2. ROUND OFF ALL SHARP CORNERS WITH 0.40 mm.
3. TOLERANCES WILL BE AS PER IS:3965-1981, UNLESS OTHERWISE SPECIFIED

PARTY'S NAME	KINGSPAN JINDAL PVT. LTD., GURGAON
PARTY'S DRAWING No.	20622 REV.1
ALLOY & TEMPER	6063 T6
DESCRIPTION	MISC. SECTION