

P-19527

E1146

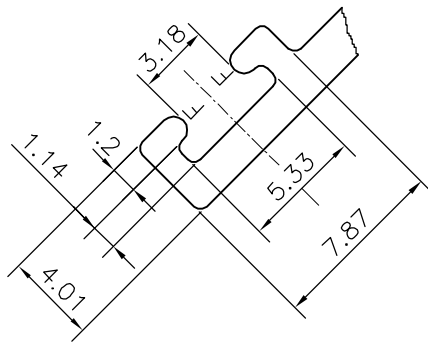

DETAIL OF "A"
SCALE 3:1

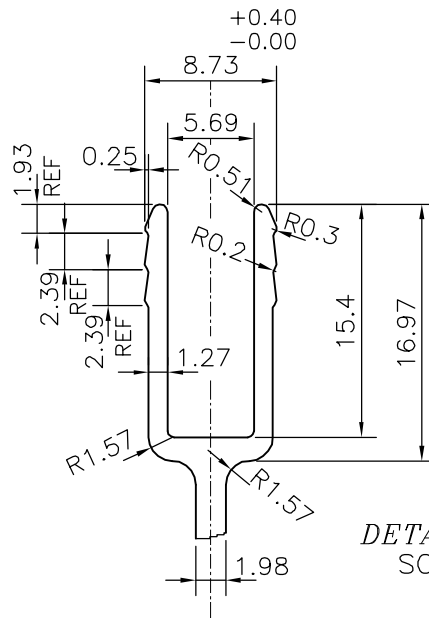

DETAIL OF "B"
SCALE 2:1

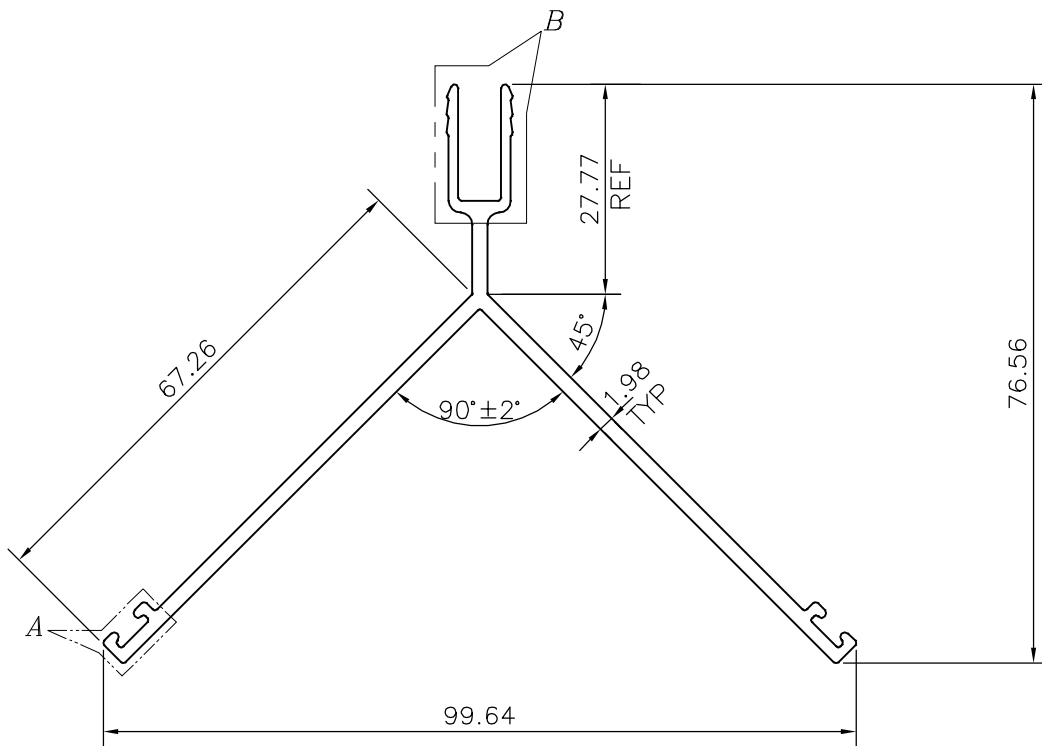

F = FULL RADIUS (4 PLACES)



SYMBOL OF QUALITY
AN ISO 9001 COMPANY

JINDAL ALUMINIUM LTD.
BANGALORE-560073 (INDIA)

	NAME	DATE
DRAWN	J.P.KAUSHIK	08-05-2019
CHECKED		
APPROVED	B.NATARAJA	09-08-2019
SCALE		1:1
AREA mm ²		353.151
PERIMETER mm.		390.129
WEIGHT kg/m		0.954
DRAWING No.	SECTION No.	
P-19527	-	
E1146	E1146	

1. ALL DIMENSIONS ARE IN mm.
2. ROUND OFF ALL SHARP CORNERS WITH 0.40 mm.
3. TOLERANCES WILL BE AS PER IS:3965-1981, UNLESS OTHERWISE SPECIFIED

PARTY'S NAME	KINGSPAN JINDAL PVT. LTD., GURGAON
PARTY'S DRAWING No.	20621 REV.1
ALLOY & TEMPER	6063 T6
DESCRIPTION	MISC. SECTION