

P-19937

E1150

EXPOSED SURFACE



SCALE: - 1:1

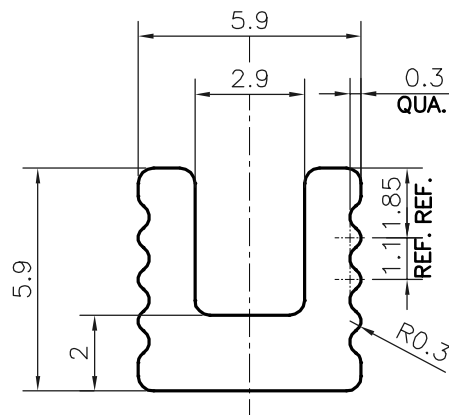

SYMBOL OF QUALITY
AN ISO 9001 COMPANY

JINDAL ALUMINIUM LTD.
BANGALORE-560073 (INDIA)

	NAME	DATE
DRAWN	DARPAN	01-08-2019
CHECKED		
APPROVED	B.NATARAJA	12-08-2019
SCALE		5:1
AREA mm ²		21.998
PERIMETER mm.		31.68
WEIGHT kg/m		0.059
DRAWING No.	SECTION No.	
P-19937	-	
E1150	E1150	

1. ALL DIMENSIONS ARE IN mm.
2. ROUND OFF ALL SHARP CORNERS WITH 0.40 mm.
3. TOLERANCES WILL BE AS PER IS:3965-1981 , UNLESS OTHERWISE SPECIFIED

PARTY'S NAME	SURFACES, BANGALORE
PARTY'S DRAWING No.	AS PER AUTOCAD DRAWING NP 13
ALLOY & TEMPER	6063 T6
DESCRIPTION	MISC. CHANNEL