

P-19939

E1152

EXPOSED SURFACE



SCALE: - 1:1

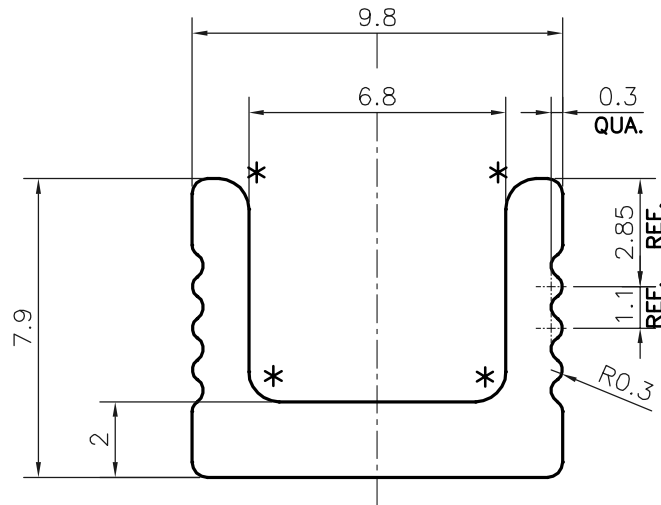

\* = R0.8mm (4 PLACES)



SYMBOL OF QUALITY  
AN ISO 9001 COMPANY

**JINDAL ALUMINIUM LTD.**  
BANGALORE-560073 (INDIA)

	NAME	DATE
DRAWN	DARPAN	01-08-2019
CHECKED		
APPROVED	B.NATARAJA	12-08-2019
SCALE		5:1
AREA mm <sup>2</sup>		35.798
PERIMETER mm.		46.793
WEIGHT kg/m		0.097
DRAWING No.		SECTION No.
P-19939		-
E1152		E1152

1. ALL DIMENSIONS ARE IN mm.
2. ROUND OFF ALL SHARP CORNERS WITH 0.40 mm.
3. TOLERANCES WILL BE AS PER IS:3965-1981, UNLESS OTHERWISE SPECIFIED

PARTY'S NAME	SURFACES..., BANGALORE
PARTY'S DRAWING No.	AS PER AUTOCAD DRAWING NP 15
ALLOY & TEMPER	6063 T6
DESCRIPTION	MISC. CHANNEL