

P-19874-1

E1155

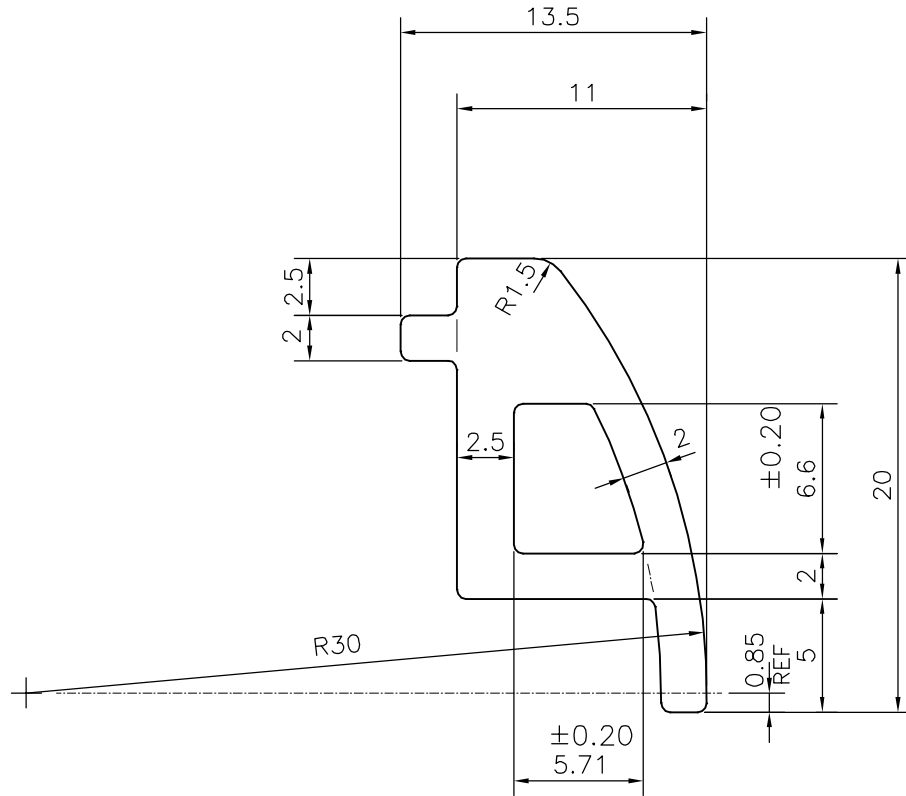
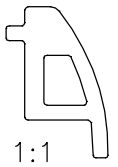

SYMBOL OF QUALITY
AN ISO 9001 COMPANY

JINDAL ALUMINIUM LTD.
BANGALORE-560073 (INDIA)

	NAME	DATE
DRAWN	J.P.KAUSHIK	27-08-2019
CHECKED		
APPROVED	B.NATARAJA	04-09-2019
SCALE		3:1
AREA mm ²		106.999
PERIMETER mm.		59.828
WEIGHT kg/m		0.289
DRAWING No.	SECTION No.	
P-19874-1	-	
E1155	E1155	

1. ALL DIMENSIONS ARE IN mm.
2. ROUND OFF ALL SHARP CORNERS WITH 0.40 mm.
3. TOLERANCES WILL BE AS PER IS:6477-1983 , UNLESS OTHERWISE SPECIFIED

PARTY'S NAME	MAS INDUSTRIES PVT. LTD., NAVI MUMBAI
PARTY'S DRAWING No.	AS PER DRAWING
ALLOY & TEMPER	6063 T6
DESCRIPTION	ORCA COP SECTION