

P-20137

E1187

EXPOSED SURFACE

1:1

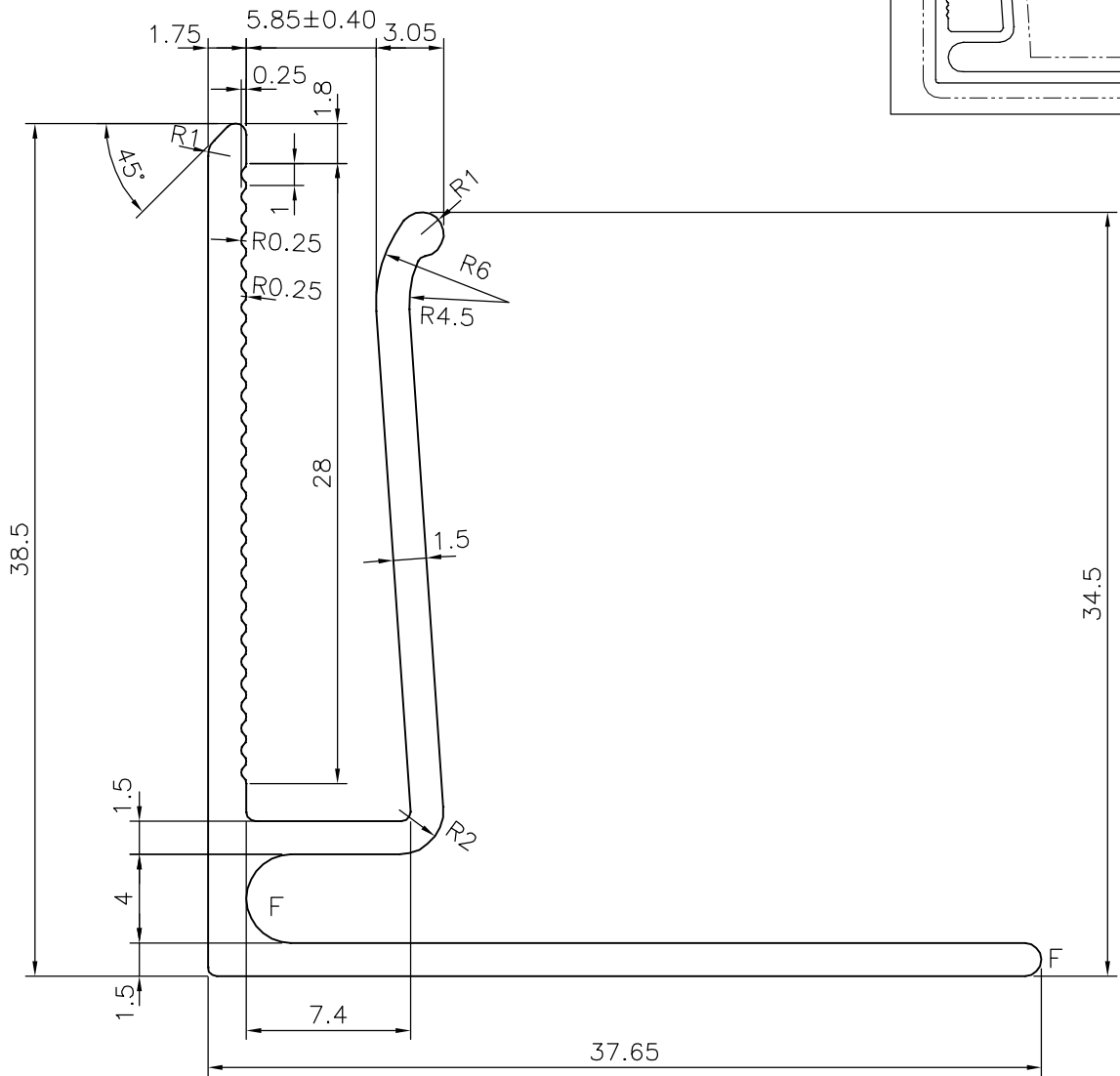

TOLERANCE CHART CD = CIRCUMSCRIBING CIRCLE

	CD ≤ 100	100 < CD ≤ 200	200 < CD ≤ 300	300 < CD ≤ 500
UPTO 10mm -	±0.25	±0.30	±0.35	±0.40
10.0 -25.0 -	±0.30	±0.40	±0.50	±0.60
25.0 -50.0 -	±0.50	±0.60	±0.80	±0.90
50.0 -100.0 -	±0.70	±0.90	±1.10	±1.30
100 - 150 -	-	±1.10	±1.30	±1.50
150 - 200 -	-	±1.3	±1.50	±1.80
200 - 300 -	-	-	±1.70	±2.10
300 - 450 -	-	-	-	±2.80

F = FULL RADIUS (2 PLACES)



SYMBOL OF QUALITY
AN ISO 9001 COMPANY

JINDAL ALUMINIUM LTD.
BANGALORE-560073 (INDIA)

	NAME	DATE
DRAWN	J.P.KAUSHIK	13-09-2019
CHECKED		
APPROVED	B.NATARAJA	20-09-2019
SCALE		3:1
AREA mm ²		173.38
PERIMETER mm.		225.122
WEIGHT kg/m		0.468
DRAWING No.	SECTION No.	
P-20137	-	
E1187	E1187	

- ALL DIMENSIONS ARE IN mm.
- ROUND OFF ALL SHARP CORNERS WITH 0.40 mm.
- TOLERANCES WILL BE AS PER BS:EN-755-9 UNLESS OTHERWISE SPECIFIED

PARTY'S NAME	CLEAR AMBER GROUP,UK
PARTY'S DRAWING No.	211327
ALLOY & TEMPER	6063 T6
DESCRIPTION	MISC. SECTION