

P-19943-1

E1192

296.5±1.50

(282.5)

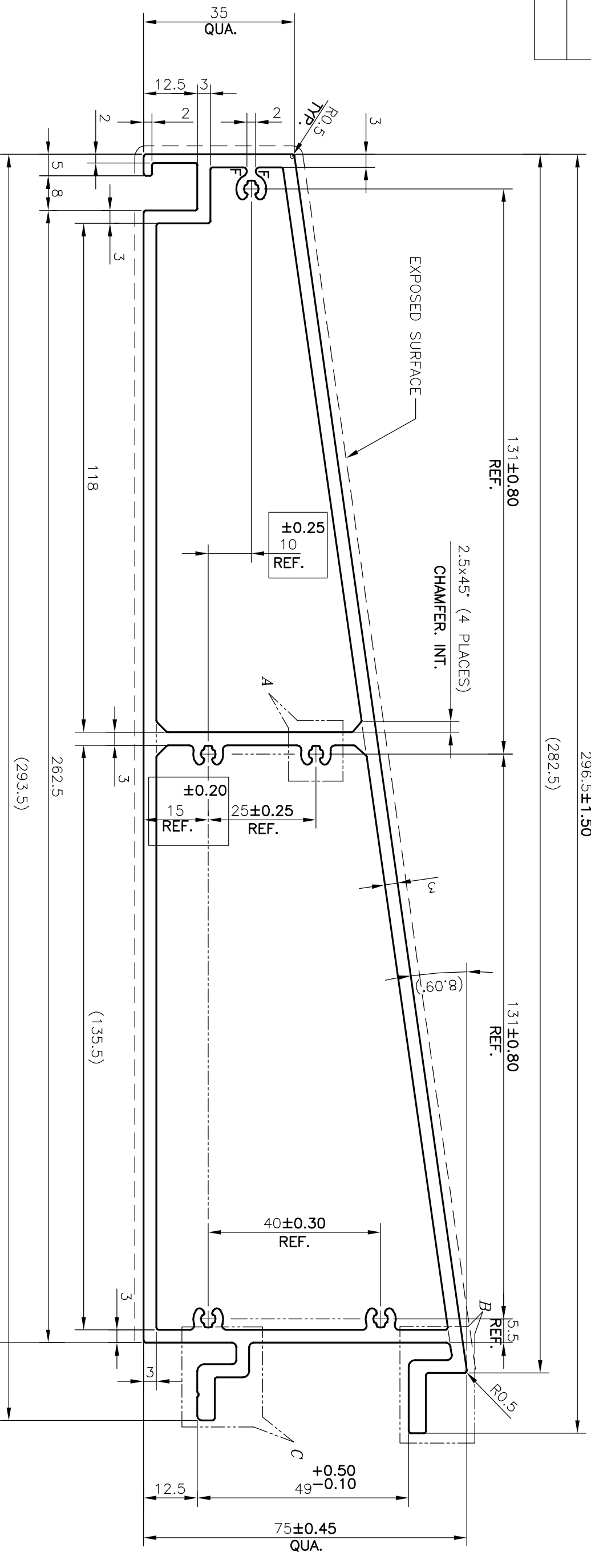

REVISÉD ON 12/11/2019:-

1. TOLERANCE ADDED ON DIMENSIONS 10±0.25.
2. TOLERANCE ADDED ON DIMENSIONS 15±0.20.
3. MEASURING BASE LINE ADDED.

V = "V" GROOVE 0.3X90° (1 PLACE)
 F = FULL RADIUS (12 PLACES)
 * = R0.9 mm (10 PLACES)

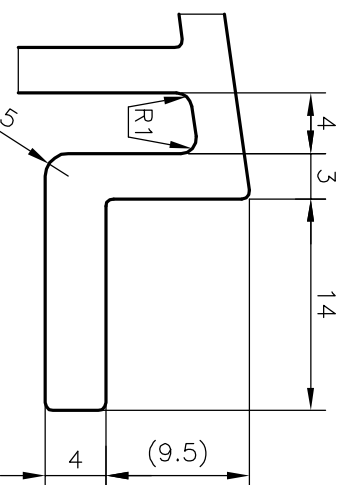
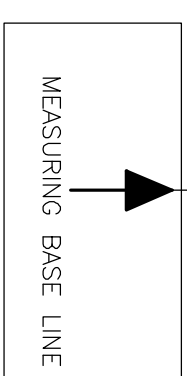

DETAIL OF "B"
SCALE 2:1

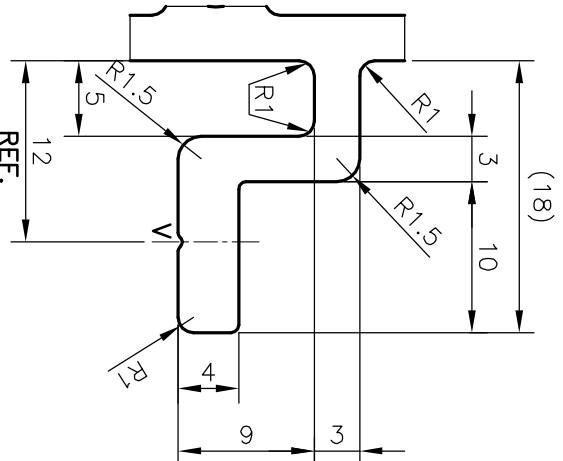

DETAIL OF "C"
SCALE 2:1

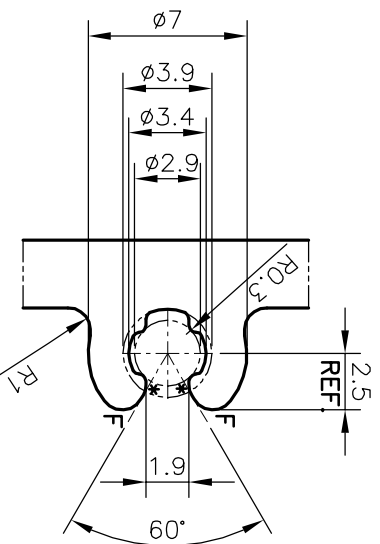

DETAIL OF "A"
SCALE 3:1

		JINDAL ALUMINIUM LTD. BANGALORE-560073 (INDIA)	
SYMBOL OF QUALITY AN ISO 9001 COMPANY			
1. ALL DIMENSIONS ARE IN mm. 2. ROUND OFF ALL SHARP CORNERS WITH 0.40 mm. 3. TOLERANCES WILL BE AS PER EN12020-2, UNLESS OTHERWISE SPECIFIED			
PARTY'S NAME	SCHUECO INDIA PRIVATE LIMITED., MUMBAI	DRAWN	NAME
PARTY'S DRAWING No.	AS PER DRAWING 9631815 FZ 0000	CHECKED	DARPAN
ALLOY & TEMPER	6060 T66	APPROVED	B.NATARAJA
DESCRIPTION	SUN SHADE PROFILE - LOUVER SECTION	SCALE	1:1
		AREA mm ²	2446.273
		PERIMETER mm.	802.961
		WEIGHT kg/m	6.605
		DRAWING No.	P-19943-1
		SECTION No.	-
			E1192
			E1192