

P-20114-2

E1199

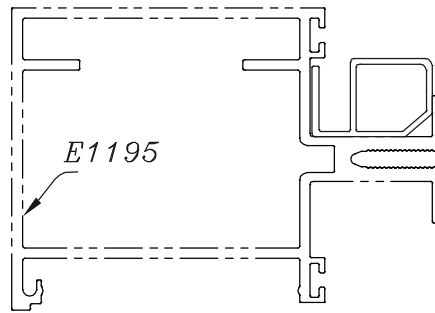

SCALE: - 0.5:1

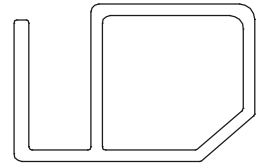

SCALE: - 1:1

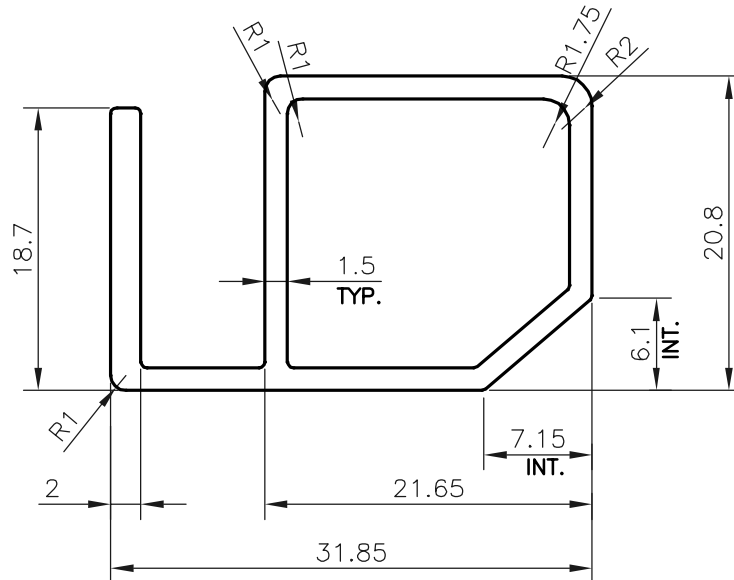

DIMENSION		TOLERANCES (EXCEPT OPEN ENDS)	TOLERANCES (OPEN ENDS)	
OVER	UP TO AND INCLUDING		E≤60	60≤E<120
-	10	±0.15	±0.15	-
10	15	±0.20	±0.20	-
15	30	±0.25	±0.25	-
30	45	±0.30	±0.30	±0.45
45	60	±0.40	±0.40	±0.55
60	90	±0.45	±0.45	±0.65
90	120	±0.60	±0.60	±0.80
120	150	±0.80	±0.80	±1.0
150	180	±1.0	±1.0	±1.3
180	240	±1.2	±1.2	±1.5
240	300	±1.5	±1.5	±1.8

NOTE:-

ALUFIT ACCEPT UPTO 0.75 mm/M
(STRAIGHTNESS, TWIST)

- | |
|---------------------------|
| 1. STRAIGHTNESS=0.50 mm/M |
| 2. TWIST=0.50 mm/M |
| 3. ANGULARITY= ±1° |
| 4. FLATNESS =0.007xWIDTH |

SYMBOL OF QUALITY
AN ISO 9001 COMPANY

JINDAL ALUMINIUM LTD.
BANGALORE-560073 (INDIA)

	NAME	DATE
DRAWN	PARVESH	27-09-2019
CHECKED		
APPROVED	B.NATARAJA	28-09-2019
SCALE		2:1
AREA mm ²		162.274
PERIMETER mm.		133.409
WEIGHT kg/m		0.438
DRAWING No.		SECTION No.
P-20114-2		-
E1199		E1199

- ALL DIMENSIONS ARE IN mm.
- ROUND OFF ALL SHARP CORNERS WITH 0.40 mm.
- TOLERANCES WILL BE AS PER BS:EN-12020-2, UNLESS OTHERWISE SPECIFIED

PARTY'S NAME	ALUFIT (INDIA) PRIVATE LIMITED, BANGALORE
PARTY'S DRAWING No.	AS PER AUTOCAD DRAWING
ALLOY & TEMPER	6063 T6
DESCRIPTION	CURTAIN WALL SECTION-SHUTTER SETTING BLOCK