

P-19982

E1217

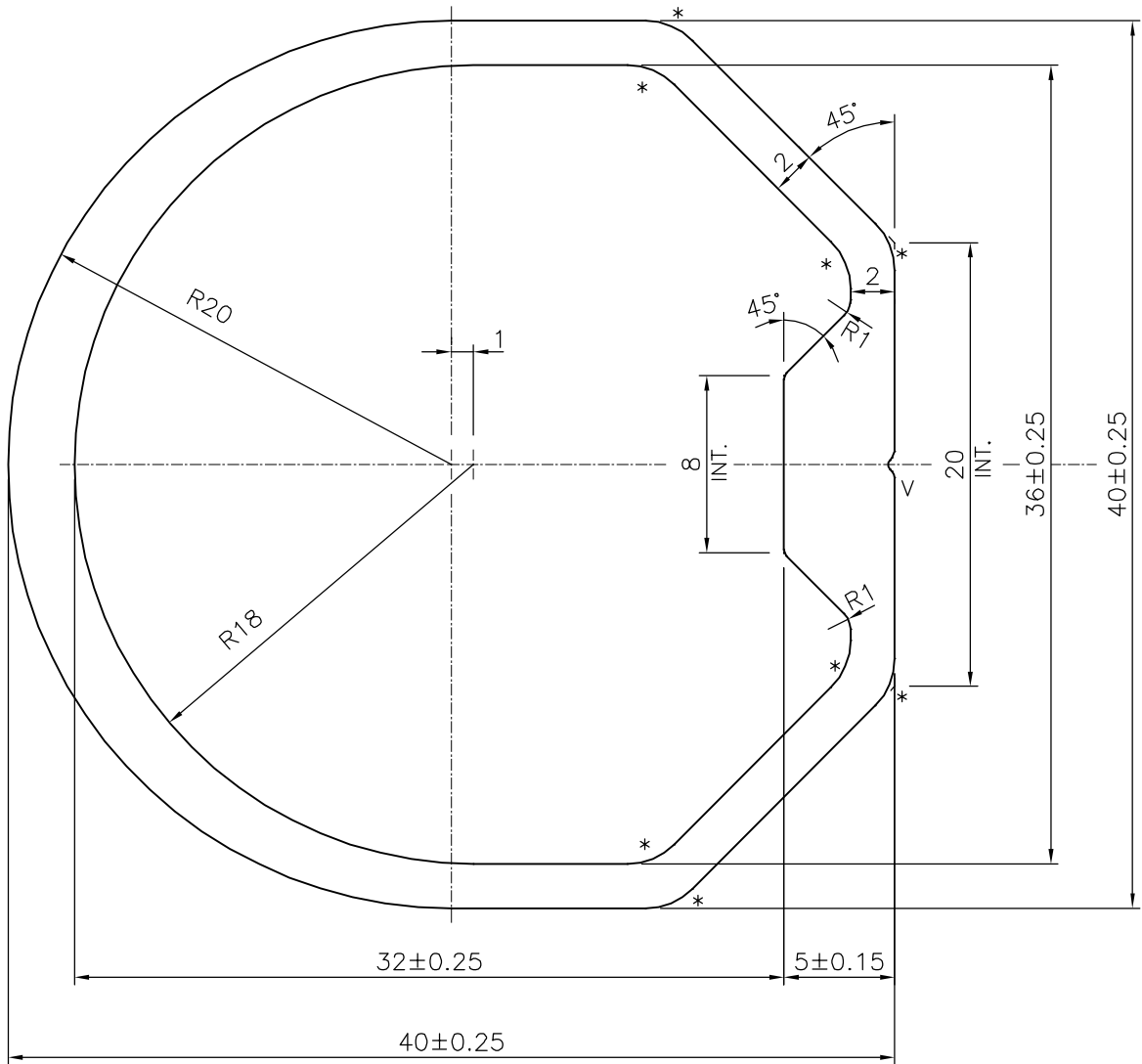

*= 3.0 RADIUS (8 PLACES)
 V= V GROOVE 0.3x90° (1 PLACE)

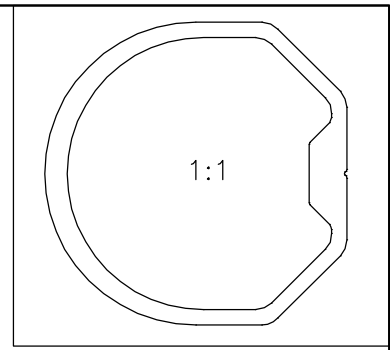

SYMBOL OF QUALITY
 AN ISO 9001 COMPANY

JINDAL ALUMINIUM LTD.
 BANGALORE-560073 (INDIA)

	NAME	DATE
DRAWN	J.P.KAUSHIK	11-08-2019
CHECKED		
APPROVED	B.NATARAJA	08-11-2019

1. ALL DIMENSIONS ARE IN mm.
2. ROUND OFF ALL SHARP CORNERS WITH 0.40 mm.
3. TOLERANCES WILL BE AS PER IS:6477-1983 , UNLESS OTHERWISE SPECIFIED

SCALE	3:1
AREA mm ²	318.19
PERIMETER mm.	130.788
WEIGHT kg/m	0.859

PARTY'S NAME	WIPRO ENTERPRISES PVT. LTD., BANGALORE
PARTY'S DRAWING No.	YPL D 0002
ALLOY & TEMPER	6005 T6
DESCRIPTION	STRALIGHT LEG SECTION

DRAWING No.	SECTION No.
P-19982	-
E1217	E1217