

P-19984

E1219

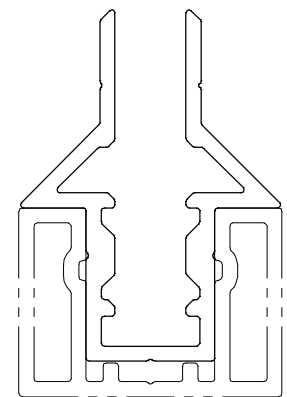
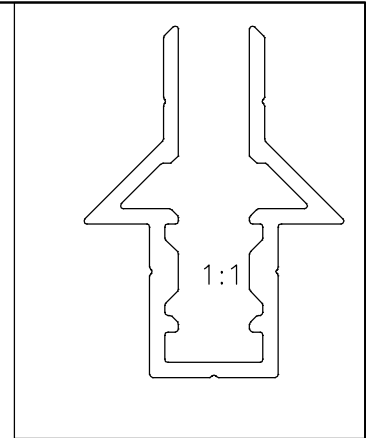
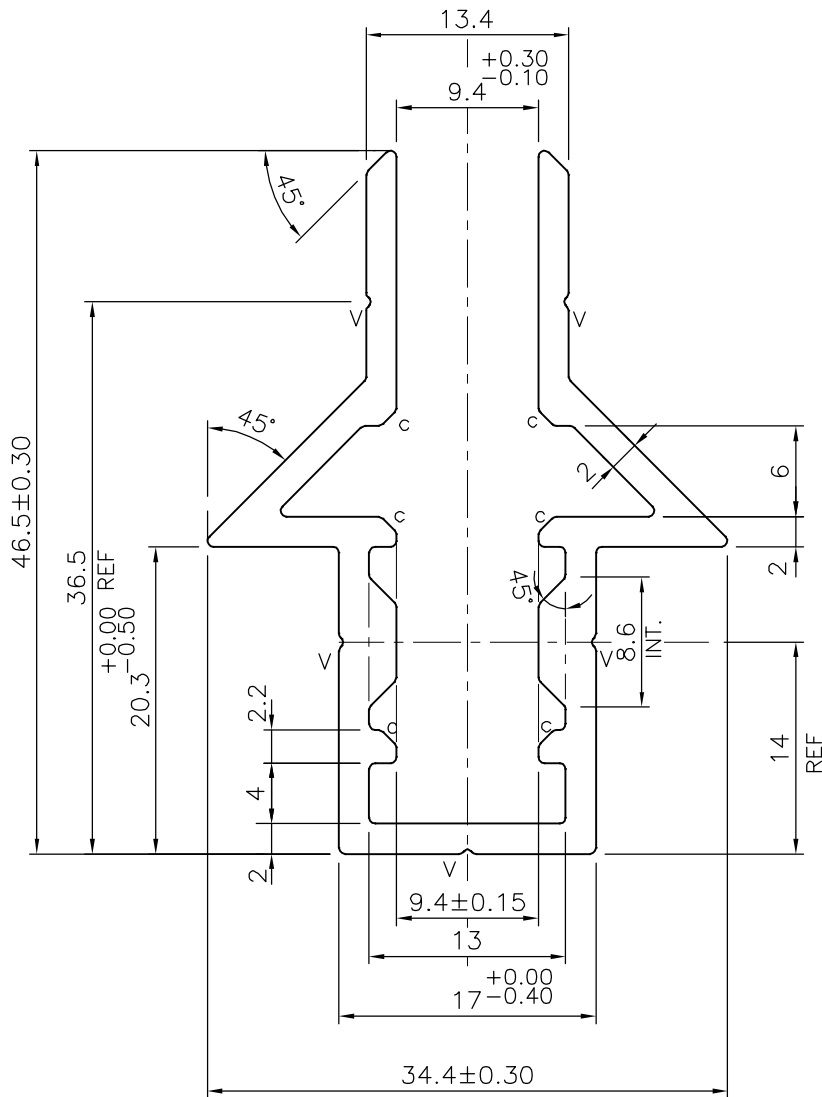

E1218

c= CHAMFER $1 \times 45^\circ$ (8 PLACES)
 V= V GROOVE $0.3 \times 90^\circ$ (5 PLACES)



SYMBOL OF QUALITY
 AN ISO 9001 COMPANY

JINDAL ALUMINIUM LTD.
 BANGALORE-560073 (INDIA)

	NAME	DATE
DRAWN	J.P.KAUSHIK	10-08-2019
CHECKED		
APPROVED	B.NATARAJA	08-11-2019
SCALE		2:1
AREA mm ²		298.135
PERIMETER mm.		271.619
WEIGHT kg/m		0.805
DRAWING No.	SECTION No.	
P-19984	-	
E1219	E1219	

1. ALL DIMENSIONS ARE IN mm.
2. ROUND OFF ALL SHARP CORNERS WITH 0.40 mm.
3. TOLERANCES WILL BE AS PER IS:3965-1981, UNLESS OTHERWISE SPECIFIED

PARTY'S NAME	WIPRO ENTERPRISES PVT. LTD., BANGALORE
PARTY'S DRAWING No.	YPL D 0010
ALLOY & TEMPER	6063 T6
DESCRIPTION	REMOVABLE SCREEN SECTION