

P-19985

E1220

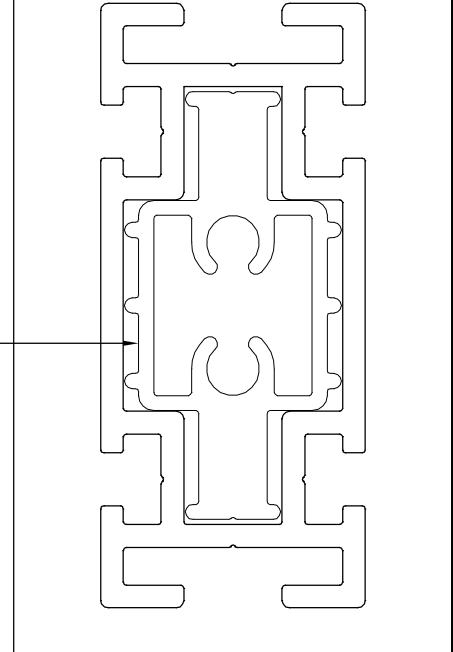

*= RADIUS 1.0 (10 PLACES)
 V= V GROOVE 0.3x90° (6 PLACES)

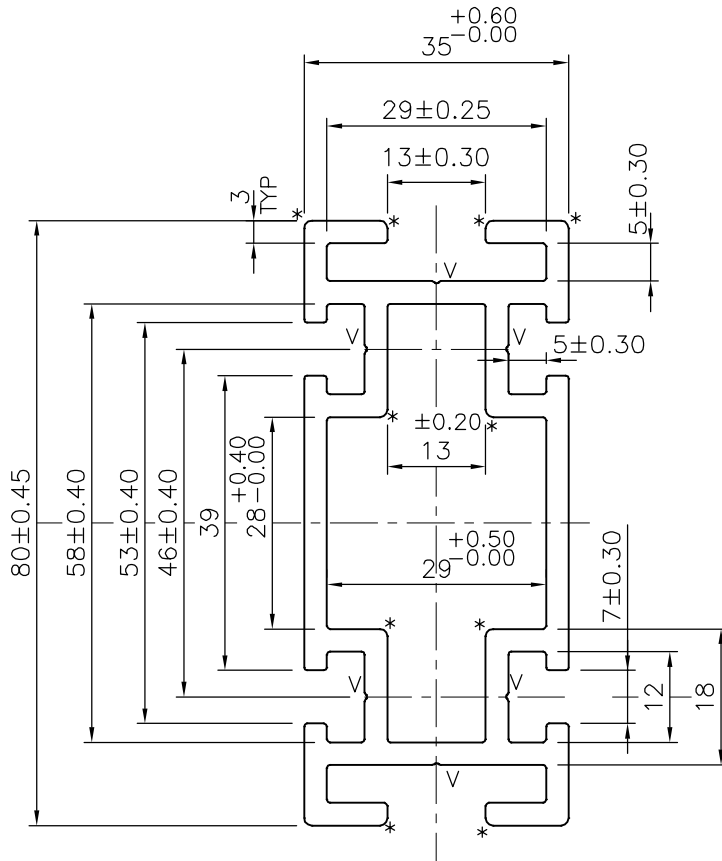

SYMBOL OF QUALITY
 AN ISO 9001 COMPANY

JINDAL ALUMINIUM LTD.
 BANGALORE-560073 (INDIA)

	NAME	DATE
DRAWN	J.P.KAUSHIK	11-08-2019
CHECKED		
APPROVED	B.NATARAJA	08-11-2019
SCALE		1:1
AREA mm ²		902.831
PERIMETER mm.		420.142
WEIGHT kg/m		2.438
DRAWING No.	SECTION No.	
P-19985	-	
E1220	E1220	

1. ALL DIMENSIONS ARE IN mm.
2. ROUND OFF ALL SHARP CORNERS WITH 0.40 mm.
3. TOLERANCES WILL BE AS PER IS:6477-1983 , UNLESS OTHERWISE SPECIFIED

PARTY'S NAME	WIPRO ENTERPRISES PVT. LTD., BANGALORE
PARTY'S DRAWING No.	YPL D 0001
ALLOY & TEMPER	6005 T6
DESCRIPTION	BEAM SECTION