

P-20378

E1227

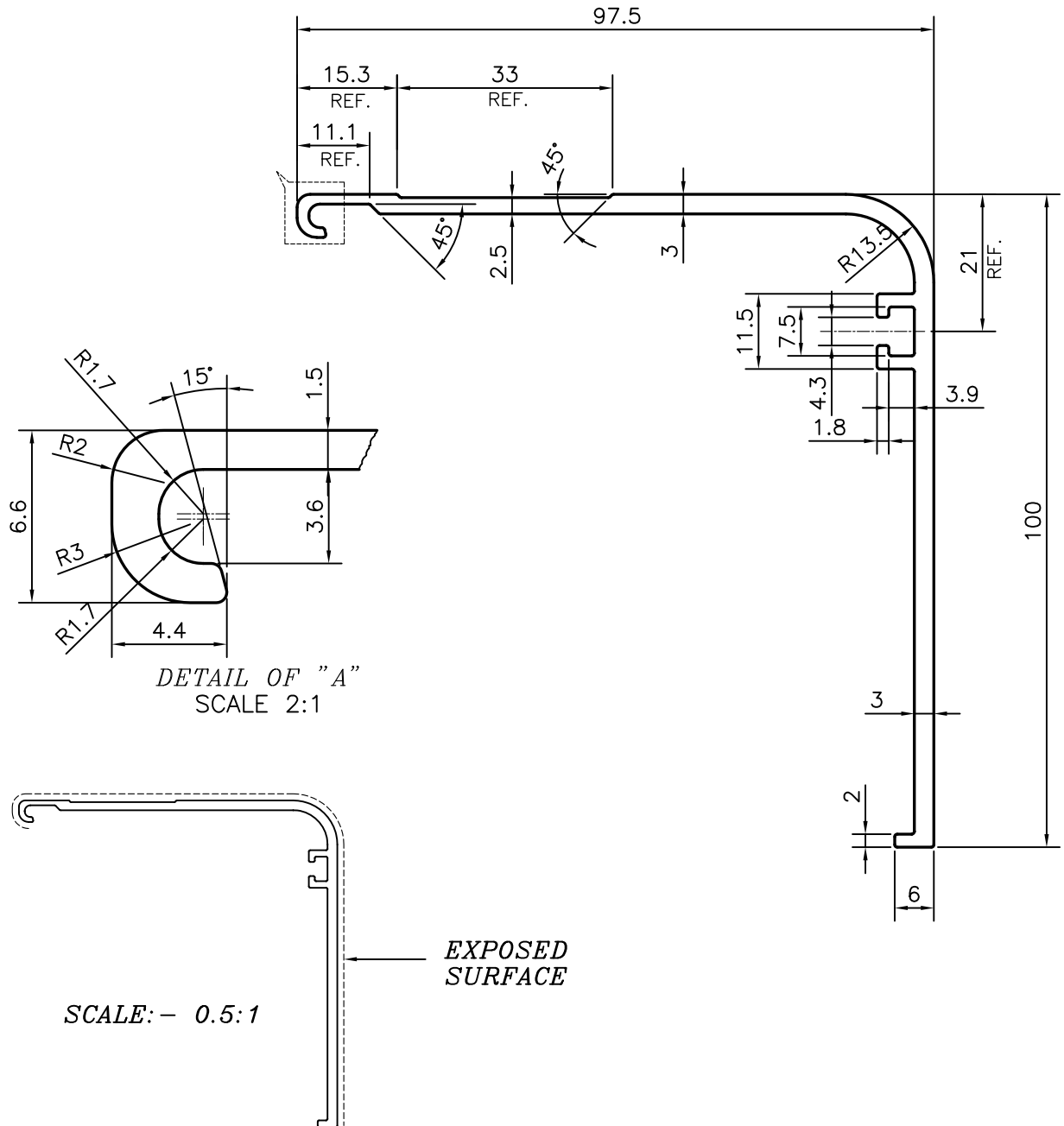

DETAIL OF "A"
SCALE 2:1

SCALE: - 0.5:1

EXPOSED SURFACE



SYMBOL OF QUALITY
AN ISO 9001 COMPANY

JINDAL ALUMINIUM LTD.
BANGALORE-560073 (INDIA)

	NAME	DATE
DRAWN	PARVESH	08-11-2019
CHECKED		
APPROVED	B.NATARAJA	11-11-2019
SCALE		1:1
AREA	mm ²	579.846
PERIMETER	mm.	427.873
WEIGHT	kg/m	1.566
DRAWING No.	SECTION No.	
P-20378	-	
E1227	E1227	

1. ALL DIMENSIONS ARE IN mm.
2. ROUND OFF ALL SHARP CORNERS WITH 0.40 mm.
3. TOLERANCES WILL BE AS PER AS/NZS 1866:1997 , UNLESS OTHERWISE SPECIFIED

PARTY'S NAME	AUTO INGRESS PTY LTD., AUSTRALIA
PARTY'S DRAWING No.	AS PER DRAWING
ALLOY & TEMPER	6063 T6
DESCRIPTION	MISC. SECTION