

P-19927-3

E1231

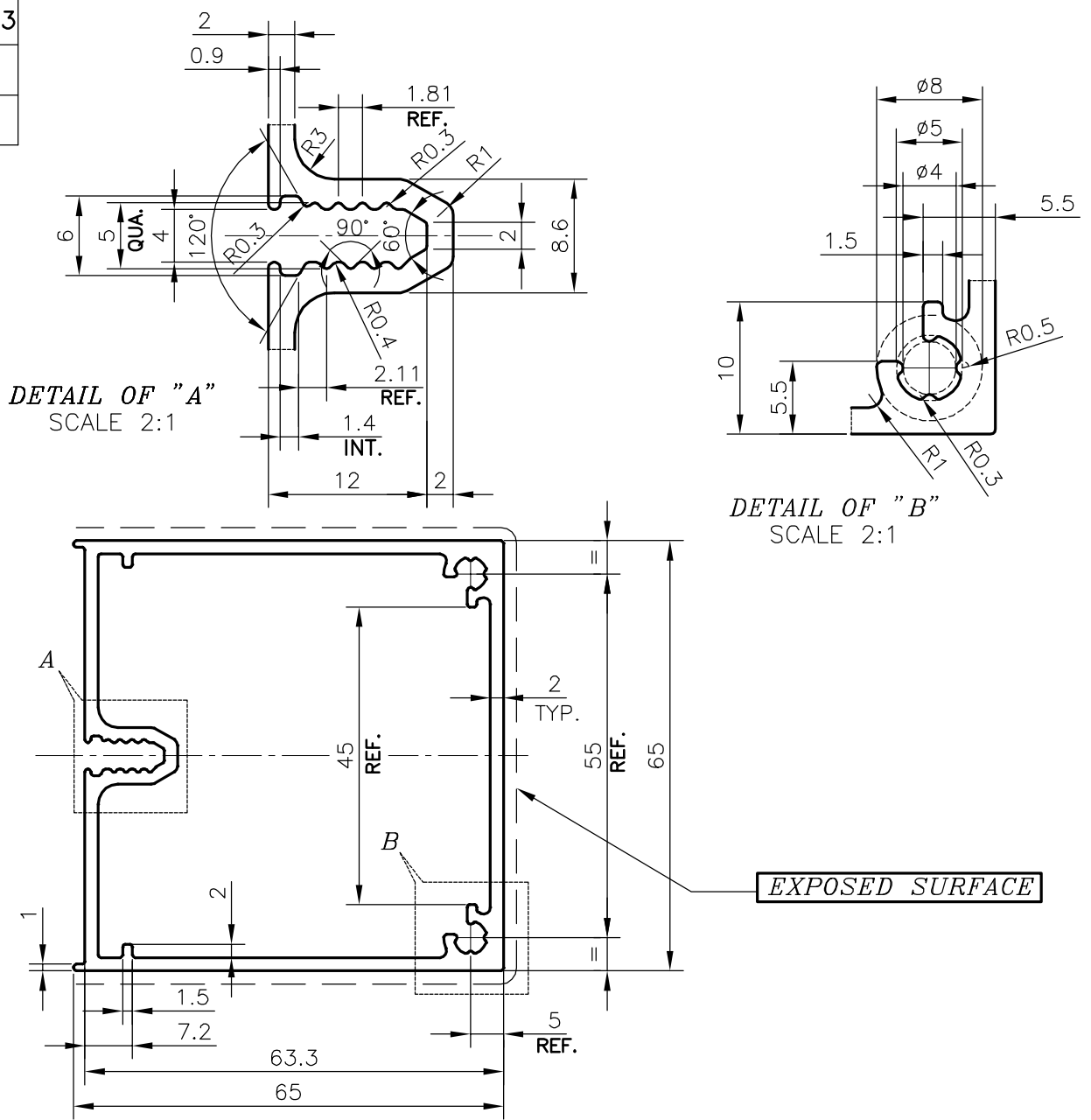

DIMENSION		TOLERANCES (EXCEPT OPEN ENDS)	TOLERANCES (OPEN ENDS)	
OVER	UP TO AND INCLUDING		E≤60	60<E≤120
-	10	±0.15	±0.15	-
10	15	±0.20	±0.20	-
15	30	±0.25	±0.25	-
30	45	±0.30	±0.30	±0.45
45	60	±0.40	±0.40	±0.55
60	90	±0.45	±0.45	±0.65
90	120	±0.60	±0.60	±0.80
120	150	±0.80	±0.80	±1.0
150	180	±1.0	±1.0	±1.3
180	240	±1.2	±1.2	±1.5
240	300	±1.5	±1.5	±1.8



SYMBOL OF QUALITY
AN ISO 9001 COMPANY

JINDAL ALUMINIUM LTD.
BANGALORE-560073 (INDIA)

	NAME	DATE
DRAWN	DARPAN	18-09-2019
CHECKED		
APPROVED	B.NATARAJA	16-11-2019
SCALE		1:1
AREA mm ²		596.274
PERIMETER mm.		289.142
WEIGHT kg/m		1.610
DRAWING No.		SECTION No.
P-19927-3		-
E1231		E1231

1. ALL DIMENSIONS ARE IN mm.
2. ROUND OFF ALL SHARP CORNERS WITH 0.40 mm.
3. TOLERANCES WILL BE AS PER EN-12020-2, UNLESS OTHERWISE SPECIFIED

PARTY'S NAME	EUROPEAN FACADE PRODUCTS., NETHERLANDS.
PARTY'S DRAWING No.	AS PER AUTOCAD DRAWING EFP 18.775
ALLOY & TEMPER	6063 T6
DESCRIPTION	TRANSOM, 65mm