

P-20446

E1267

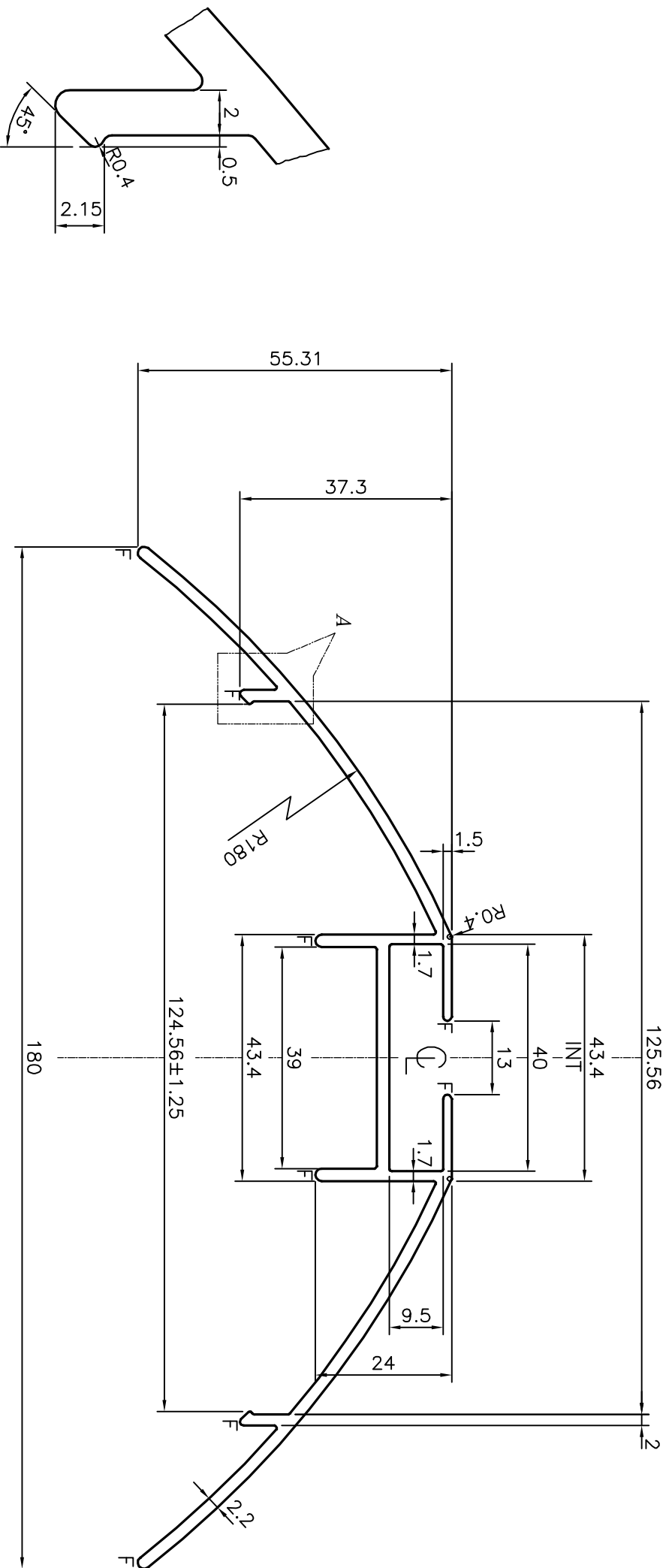

DETAIL OF "A"  
SCALE 4:1

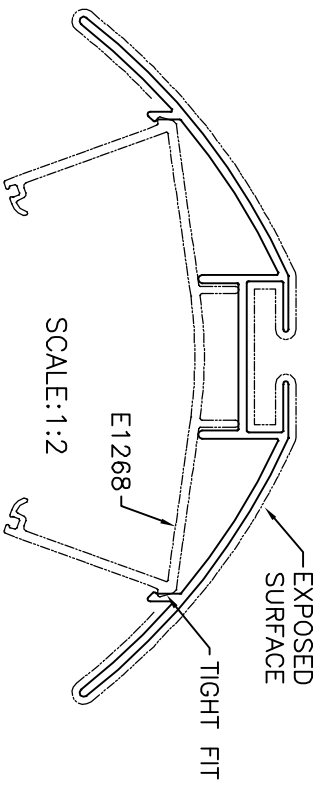
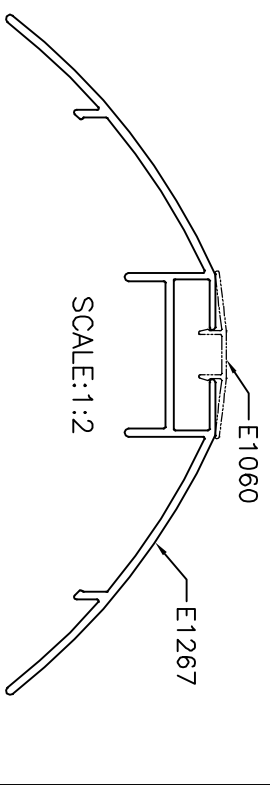
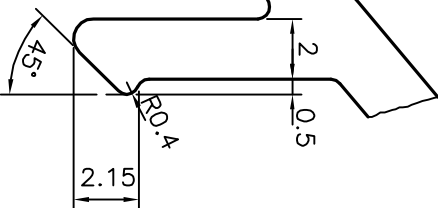

TOLERANCE CHART CD = CIRCUMSCRIBING CIRCLE

CD ≤ 100	100 < CD ≤ 200	200 < CD ≤ 300	300 < CD ≤ 500
UP TO 10mm - ±0.25	±0.30	±0.35	±0.40
10.0 - 25.0 - ±0.30	±0.40	±0.50	±0.60
25.0 - 50.0 - ±0.50	±0.60	±0.80	±0.90
50.0 - 100.0 - ±0.70	±0.90	±1.10	±1.30
100 - 150 - -	±1.10	±1.30	±1.50
150 - 200 - -	±1.3	±1.50	±1.80
200 - 300 - -	-	±1.70	±2.10
300 - 450 - -	-	-	±2.80

F = FULL RADIUS (8 PLACES)

 <p><b>JINDAL ALUMINIUM LTD.</b> BANGALORE-560073 (INDIA)</p>		<p>SYMBOL OF QUALITY AN ISO 9001 COMPANY</p>
<p>1. ALL DIMENSIONS ARE IN mm. 2. ROUND OFF ALL SHARP CORNERS WITH 0.40 mm. 3. TOLERANCES WILL BE AS PER BS:EN-755-9 UNLESS OTHERWISE SPECIFIED</p>		
PARTY'S NAME	CLEAR AMBER GROUP, UK	
PARTY'S DRAWING No.	206654	
ALLOY & TEMPER	6063 T6	
DESCRIPTION	RIDGE COVER SECTION	
DRAWN	NAME	DATE
CHECKED	J.P. KAUSHIK	20-11-2019
APPROVED	B. NATARAJA	23-11-2019
SCALE	1:1	
AREA	mm <sup>2</sup>	634.471
PERIMETER	mm.	601.692
WEIGHT	kg/m	1.713
DRAWING No.	SECTION No.	
P-20446	-	
E1267	E1267	