

P-20447

E1268

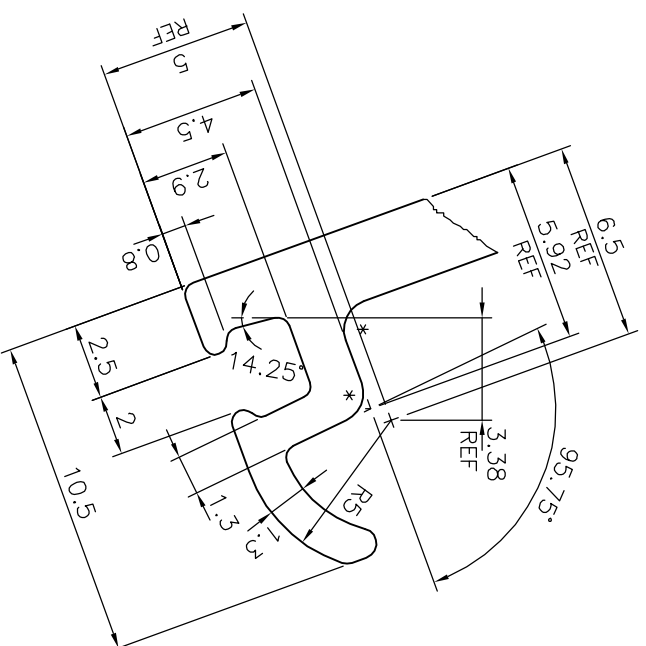

DETAIL OF "A"
SCALE 4:1

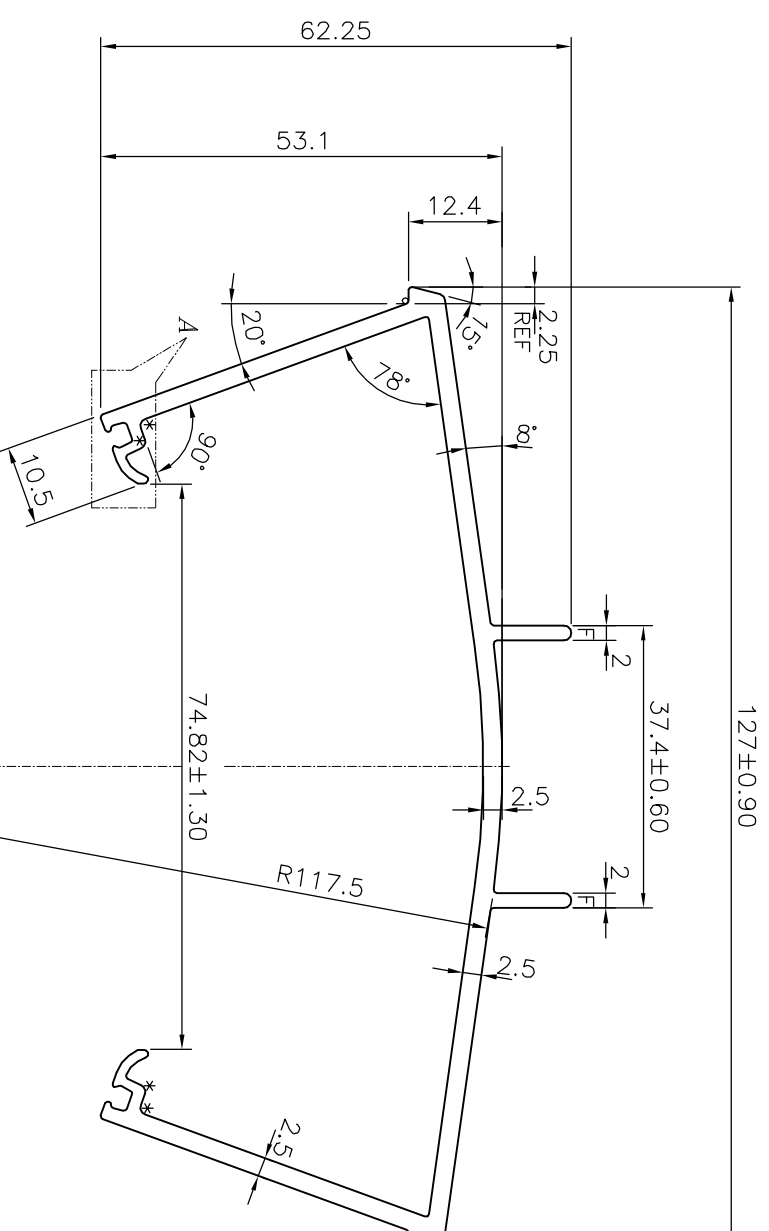

TOLERANCE CHART CD = CIRCUMSCRIBING CIRCLE

CD≤100	100<CD≤200	200<CD≤300	300<CD≤500
UPTO 10mm - ±0.25	±0.30	±0.35	±0.40
10.0 -25.0 - ±0.30	±0.40	±0.50	±0.60
25.0 -50.0 - ±0.50	±0.60	±0.80	±0.90
50.0 -100.0 - ±0.70	±0.90	±1.10	±1.30
100 - 150 - -	±1.10	±1.30	±1.50
150 - 200 - -	±1.30	±1.50	±1.80
200 - 300 - -	-	±1.50	±2.10
300 - 450 - -	-	±1.70	±2.80

F = FULL RADIUS (2 PLACES)
* = 1.0 RADIUS (4 PLACES)

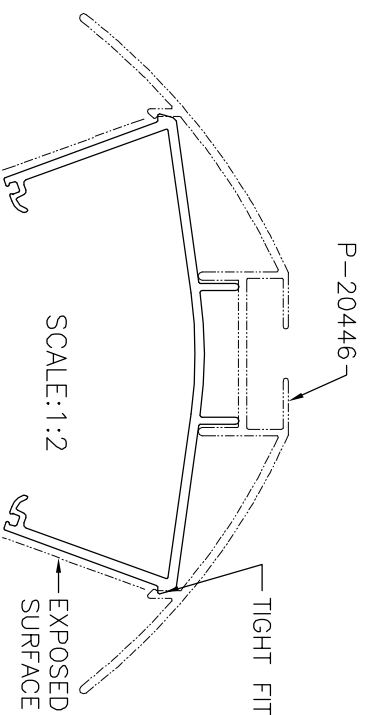

JINDAL
SYMBOL OF QUALITY
AN ISO 9001 COMPANY
JINDAL ALUMINIUM LTD.
BANGALORE-560073 (INDIA)

1. ALL DIMENSIONS ARE IN mm.
2. ROUND OFF ALL SHARP CORNERS WITH 0.40 mm.
3. TOLERANCES WILL BE AS PER BS:EN-755-9 UNLESS OTHERWISE SPECIFIED

PARTY'S NAME	CLEAR AMBER GROUP, UK	SCALE	1:1
PARTY'S DRAWING No.	206655	AREA mm ²	621.645
ALLOY & TEMPER	6063 T6	PERIMETER mm.	524.611
DESCRIPTION	RIDGE CAP SECTION	WEIGHT kg/m	1.678
		DRAWING No.	SECTION No.
		P-20447	-
		E1268	E1268

DRAWN	NAME	DATE
J.P.KAUSHIK		20-11-2019

CHECKED	
APPROVED	B.NATARAJA 23-11-2019