

P-20765-1

E1300

EXPOSED SURFACE

1:1

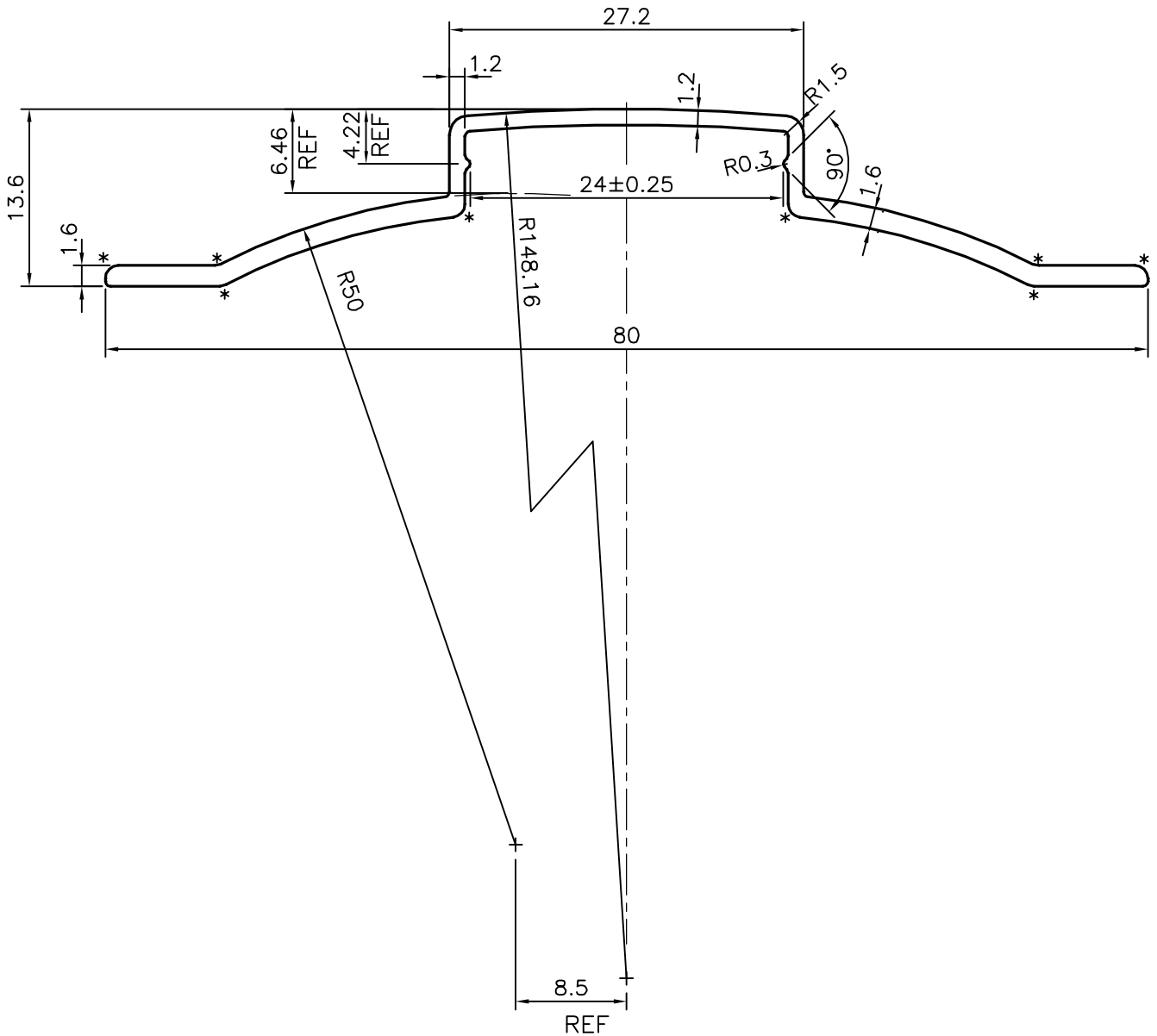
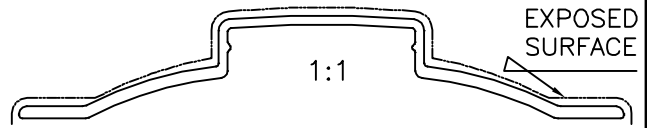
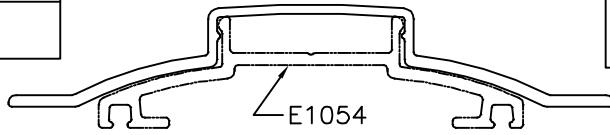

* = 1.0 RADIUS (8 PLACES)



SYMBOL OF QUALITY
AN ISO 9001 COMPANY

JINDAL ALUMINIUM LTD.
BANGALORE-560073 (INDIA)

	NAME	DATE
DRAWN	J.P.KAUSHIK	20-02-2020
CHECKED		
APPROVED	B.NATARAJA	27-02-2020
SCALE		2:1
AREA	mm ²	134.58
PERIMETER	mm.	188.999
WEIGHT	kg/m	0.363
DRAWING No.	SECTION No.	
P-20765-1	-	
E1300	E1300	

1. ALL DIMENSIONS ARE IN mm.
2. ROUND OFF ALL SHARP CORNERS WITH 0.40 mm.
3. TOLERANCES WILL BE AS PER BS:EN-755-9 UNLESS OTHERWISE SPECIFIED

PARTY'S NAME	CLEAR AMBER GROUP, UK
PARTY'S DRAWING No.	206673
ALLOY & TEMPER	6063 T6
DESCRIPTION	HIP TOP CLIP SECTION