

P-20703-4

E1306

DETAIL OF "A"
SCALE 2:1

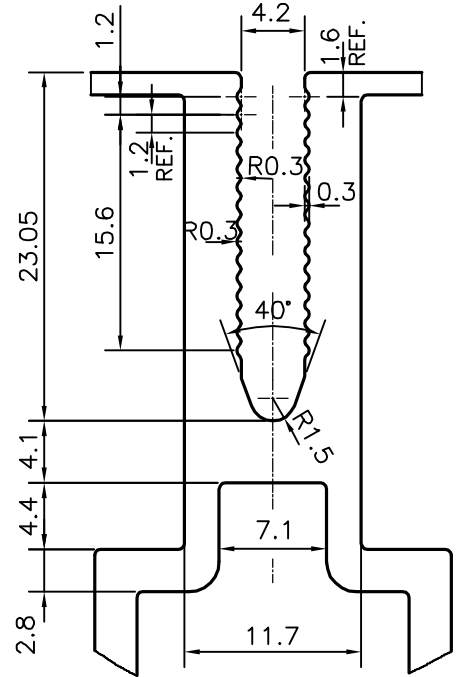
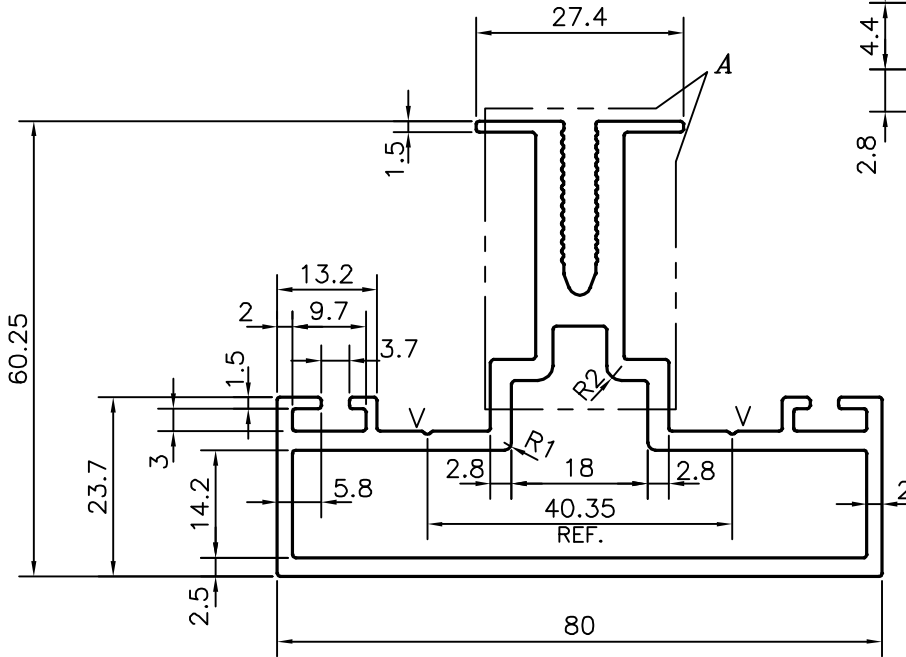

NOTE:-
ALUFIT ACCEPT UPTO 0.75 mm/M
(STRAIGHTNESS, TWIST)

- 1. STRAIGHTNESS=0.50 mm/M
- 2. TWIST=0.50 mm/M
- 3. ANGULARITY= ±1°
- 4. FLATNESS =0.007xWIDTH

V = V GROOVE 0.3x90° (2 PLACES)

DIMENSION		TOLERANCES (EXCEPT OPEN ENDS)	TOLERANCES (OPEN ENDS)	
OVER	UP TO AND INCLUDING		E≤60	60≤E<120
-	10	±0.15	±0.15	-
10	15	±0.20	±0.20	-
15	30	±0.25	±0.25	-
30	45	±0.30	±0.30	±0.45
45	60	±0.40	±0.40	±0.55
60	90	±0.45	±0.45	±0.65
90	120	±0.60	±0.60	±0.80
120	150	±0.80	±0.80	±1.0
150	180	±1.0	±1.0	±1.3
180	240	±1.2	±1.2	±1.5
240	300	±1.5	±1.5	±1.8



SYMBOL OF QUALITY
AN ISO 9001 COMPANY

JINDAL ALUMINIUM LTD.
BANGALORE-560073 (INDIA)

- 1. ALL DIMENSIONS ARE IN mm.
- 2. ROUND OFF ALL SHARP CORNERS WITH 0.40 mm.
- 3. TOLERANCES WILL BE AS PER BS:EN-12020-2 UNLESS OTHERWISE SPECIFIED

		NAME	DATE
PARTY'S NAME		ALUFIT (INDIA) PVT. LTD., BANGALORE	
PARTY'S DRAWING No.		AS PER DRAWING	
ALLOY & TEMPER		6063 T6	
DESCRIPTION		MULLION SECTION	
		DRAWN	J.P.KAUSHIK
		CHECKED	
		APPROVED	B.NATARAJA
		SCALE	1:1
		AREA mm ²	805.051
		PERIMETER mm.	414.98
		WEIGHT kg/m	2.174
		DRAWING No.	P-20703-4
		SECTION No.	-
			E1306
			E1306