

P-20739

E1307

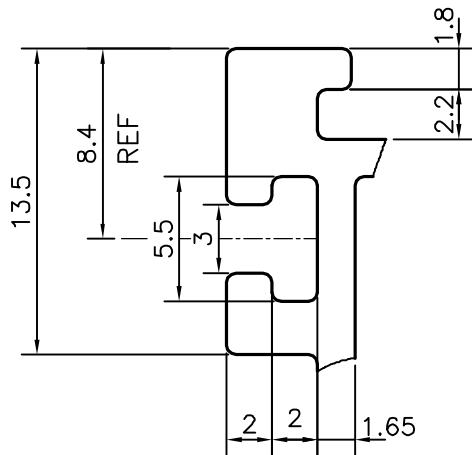

DETAIL OF "A"  
SCALE 3:1

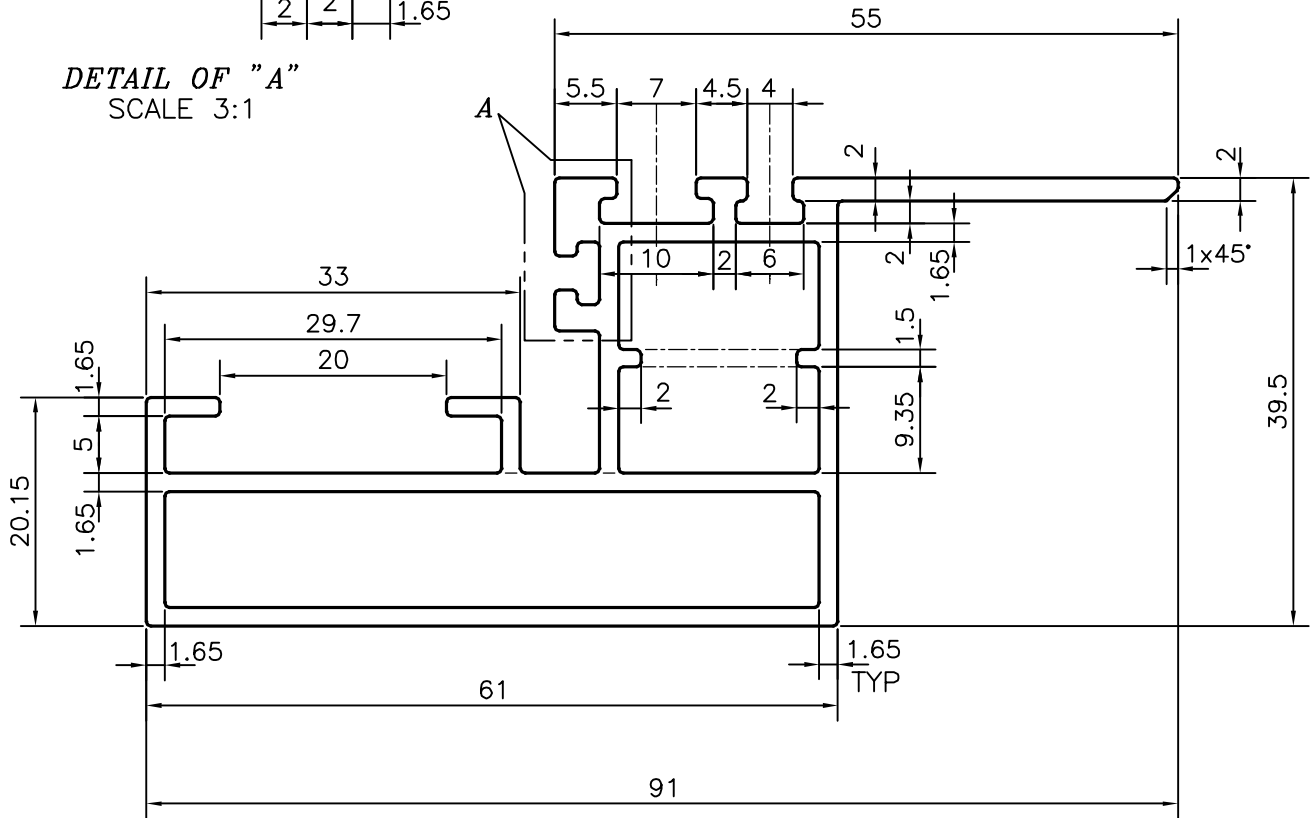
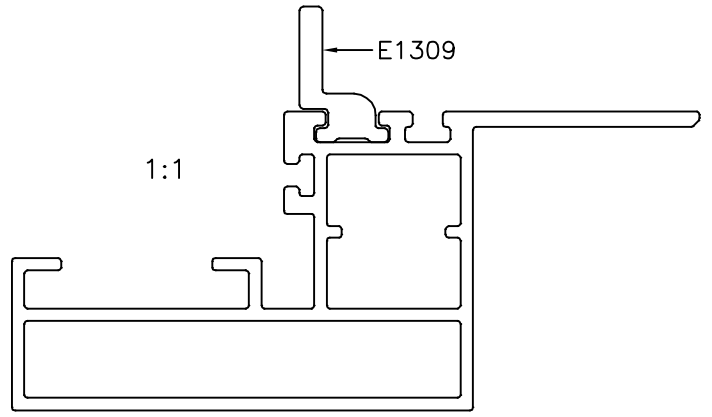

TOLERANCES ON OVERALL WIDTHS & WIDTHS ACROSS FLATS OF BARS, & REGULAR SECTIONS

UPTO 6.40mm - ±0.20	UPTO 32.0mm - ±0.38	UPTO 120.0mm - ±0.85	<b>1. STRAIGHTNESS=1.0mm/M</b> <b>2. TWIST=1.0mm/M</b> <b>3. ANGULARITY= ±1°</b> <b>4. FLATNESS =0.007xWIDTH</b>
UPTO 10.0mm - ±0.23	UPTO 50.0mm - ±0.46	UPTO 160.0mm - ±1.02	
UPTO 12.0mm - ±0.25	UPTO 60.0mm - ±0.53	UPTO 200.0mm - ±1.14	
UPTO 16.0mm - ±0.28	UPTO 80.0mm - ±0.69	UPTO 250.0mm - ±1.40	
UPTO 25.0mm - ±0.30	UPTO 100.0mm - ±0.75	UPTO 300.0mm - ±1.65	



SYMBOL OF QUALITY  
AN ISO 9001 COMPANY

**JINDAL ALUMINIUM LTD.**  
BANGALORE-560073 (INDIA)

	NAME	DATE
DRAWN	J.P.KAUSHIK	15-02-2020
CHECKED		
APPROVED	B.NATARAJA	29-02-2020
SCALE		1.5:1
AREA mm <sup>2</sup>		506.78
PERIMETER mm.		345.997
WEIGHT kg/m		1.368
DRAWING No.	SECTION No.	
P-20739	-	
E1307	E1307	

- ALL DIMENSIONS ARE IN mm.
- ROUND OFF ALL SHARP CORNERS WITH 0.40 mm.
- TOLERANCES WILL BE AS PER IS:6477-1983, UNLESS OTHERWISE SPECIFIED

PARTY'S NAME	ALUFIT INDIA PVT. LTD., BANGALORE
PARTY'S DRAWING No.	AS PER DRAWING
ALLOY & TEMPER	6063 T6
DESCRIPTION	DGU-SHUTTER SECTION