

P-20928

E1335

EXPOSED SURFACE

1:1

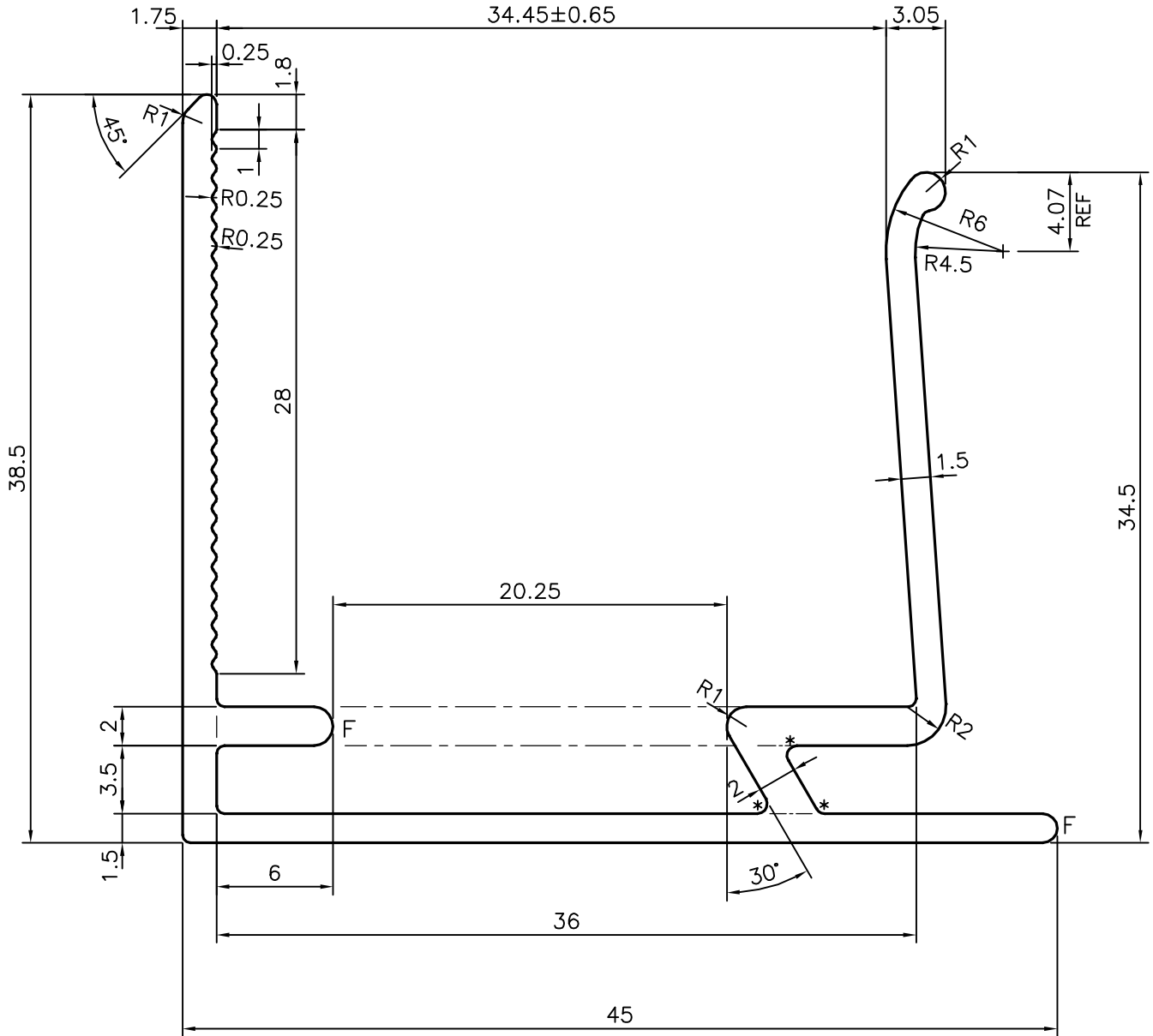

\* = 0.5 RADIUS (3 PLACES)  
 F = FULL RADIUS (2 PLACES)



SYMBOL OF QUALITY  
 AN ISO 9001 COMPANY

**JINDAL ALUMINIUM LTD.**  
 BANGALORE-560073 (INDIA)

	NAME	DATE
DRAWN	J.P.KAUSHIK	25-04-2020
CHECKED		
APPROVED	B.NATARAJA	18-07-2020
SCALE		3:1
AREA	mm <sup>2</sup>	211.616
PERIMETER	mm.	262.362
WEIGHT	kg/m	0.571
DRAWING No.	SECTION No.	
P-20928	-	
E1335	E1335	

1. ALL DIMENSIONS ARE IN mm.
2. ROUND OFF ALL SHARP CORNERS WITH 0.40 mm.
3. TOLERANCES WILL BE AS PER BS:EN-755-9 UNLESS OTHERWISE SPECIFIED

PARTY'S NAME	CLEAR AMBER GROUP, UK
PARTY'S DRAWING No.	203384
ALLOY & TEMPER	6063 T6
DESCRIPTION	GLAZING SECTION