

P-21107

E1346

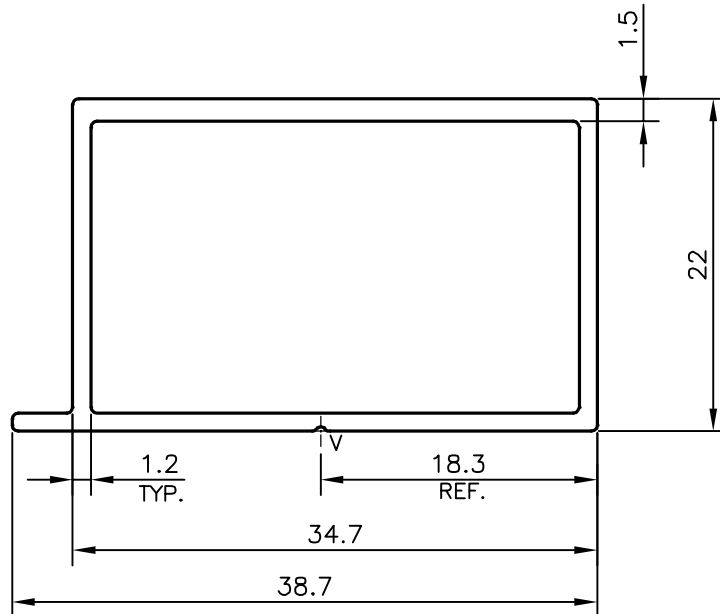

SCALE: - 1:1



V = VEE GROOVE 0.3x90° (1 PLACE)

TOLERANCES ON OVERALL WIDTHS & WIDTHS ACROSS FLATS OF BARS, & REGULAR SECTIONS

UPTO 6.40mm - ±0.20
 UPTO 10.0mm - ±0.23
 UPTO 12.0mm - ±0.25
 UPTO 16.0mm - ±0.28
 UPTO 25.0mm - ±0.30

UPTO 32.0mm - ±0.38
 UPTO 50.0mm - ±0.46
 UPTO 60.0mm - ±0.53
 UPTO 80.0mm - ±0.69
 UPTO 100.0mm - ±0.75

UPTO 120.0mm - ±0.85
 UPTO 160.0mm - ±1.02
 UPTO 200.0mm - ±1.14
 UPTO 250.0mm - ±1.40
 UPTO 300.0mm - ±1.65

1. STRAIGHTNESS=1.0mm/M
2. TWIST=1.0mm/M
3. ANGULARITY= ±1°
4. FLATNESS =0.007xWIDTH



SYMBOL OF QUALITY
 AN ISO 9001 COMPANY

JINDAL ALUMINIUM LTD.
 BANGALORE-560073 (INDIA)

	NAME	DATE
DRAWN	PARVESH	22-06-2020
CHECKED		
APPROVED	B.NATARAJA	10-08-2020

1. ALL DIMENSIONS ARE IN mm.
2. ROUND OFF ALL SHARP CORNERS WITH 0.40 mm.
3. TOLERANCES WILL BE AS PER IS:6477-1983 , UNLESS OTHERWISE SPECIFIED

SCALE	2:1
AREA mm ²	144.642
PERIMETER mm.	120.558
WEIGHT kg/m	0.391

PARTY'S NAME	ALUFIT (INDIA) PRIVATE LIMITED, BANGALORE
PARTY'S DRAWING No.	AS PER AUTOCAD DRAWING-AL-13
ALLOY & TEMPER	6063 T6
DESCRIPTION	CURTAIN WALL SECTION-SPANDREL SPACER-2

DRAWING No.	SECTION No.
P-21107	-
E1346	E1346