

P-21115

E1356

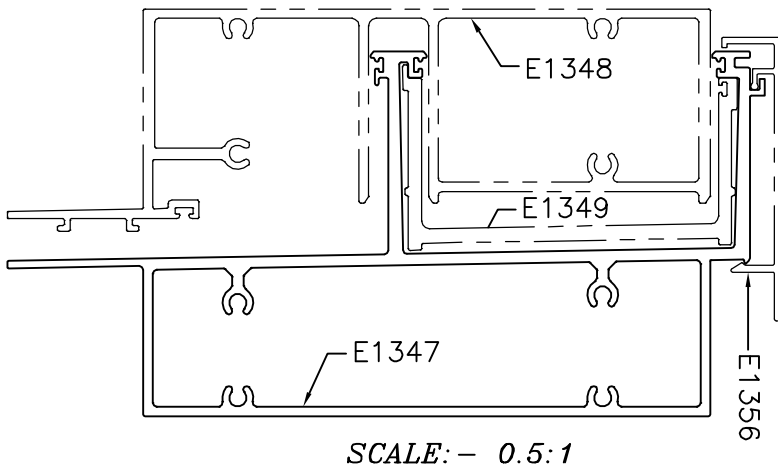
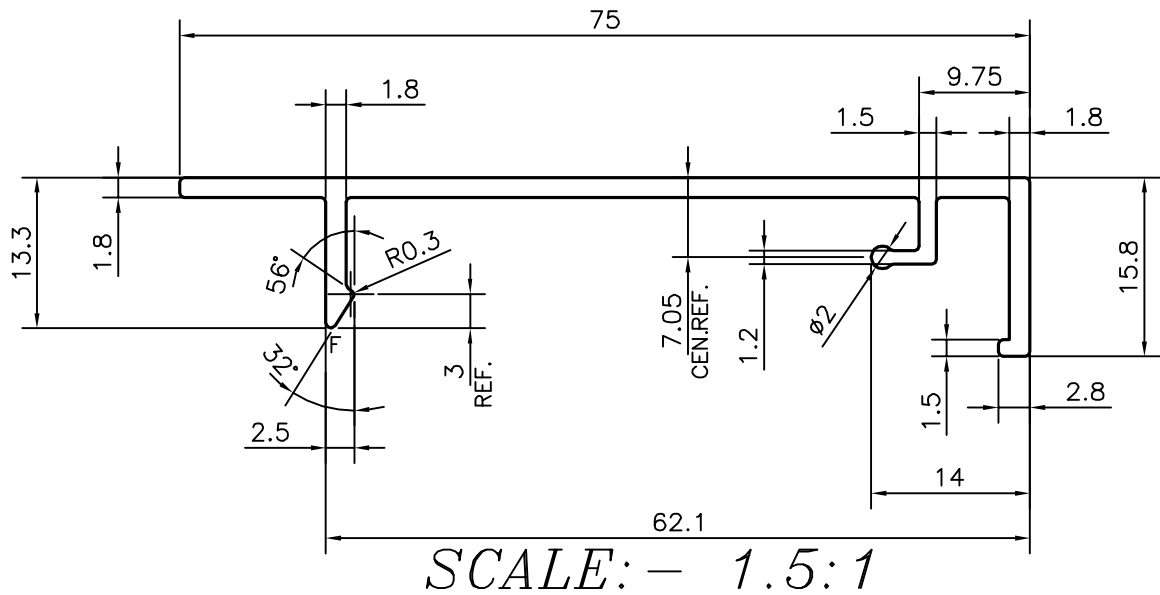
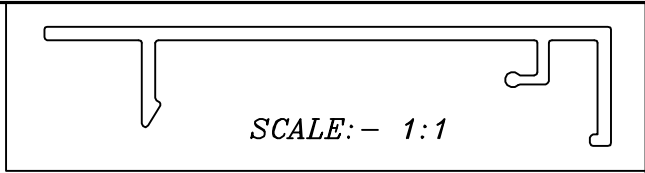

F=FULL RADIUS (06 PLACES)

TOLERANCES ON OVERALL WIDTHS & WIDTHS ACROSS FLATS OF BARS, & REGULAR SECTIONS

UPTO 6.40mm - ±0.20	UPTO 32.0mm - ±0.38	UPTO 120.0mm - ±0.85	1. STRAIGHTNESS=1.0mm/M 2. TWIST=1.0mm/M 3. ANGULARITY= ±1° 4. FLATNESS =0.007xWIDTH
UPTO 10.0mm - ±0.23	UPTO 50.0mm - ±0.46	UPTO 160.0mm - ±1.02	
UPTO 12.0mm - ±0.25	UPTO 60.0mm - ±0.53	UPTO 200.0mm - ±1.14	
UPTO 16.0mm - ±0.28	UPTO 80.0mm - ±0.69	UPTO 250.0mm - ±1.40	
UPTO 25.0mm - ±0.30	UPTO 100.0mm - ±0.75	UPTO 300.0mm - ±1.65	



SYMBOL OF QUALITY
AN ISO 9001 COMPANY

JINDAL ALUMINIUM LTD.
BANGALORE-560073 (INDIA)

	NAME	DATE
DRAWN	DARPAN	22-06-2020
CHECKED		
APPROVED	B.NATARAJA	11-08-2020

- ALL DIMENSIONS ARE IN mm.
- ROUND OFF ALL SHARP CORNERS WITH 0.40 mm.
- TOLERANCES WILL BE AS PER IS:3965-1981 , UNLESS OTHERWISE SPECIFIED

SCALE	1.5:1
AREA mm ²	196.743
PERIMETER mm.	224.2
WEIGHT kg/m	0.531

PARTY'S NAME	ALUFIT (INDIA) PRIVATE LIMITED., BANGALORE
PARTY'S DRAWING No.	AS PER AUTOCAD DRAWING-AL-14
ALLOY & TEMPER	6063 T6
DESCRIPTION	CURTAIN WALL SECTION-ALUM SKIRTING PROFILE

DRAWING No.	SECTION No.
P-21115	-
E1356	E1356