

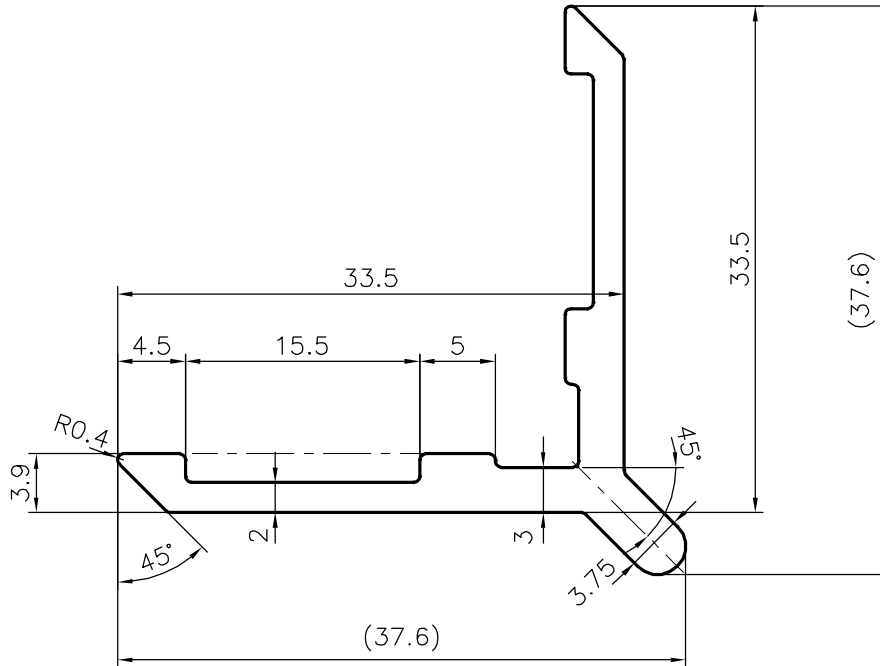

P-20527

E1368

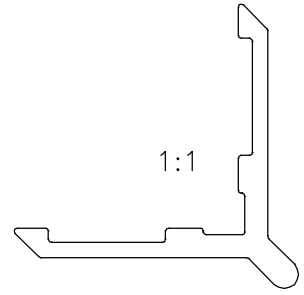

TOLERANCES ON OVERALL DIMENSIONS OF HOLLOW SECTIONS

UPTO 20.0mm - ±0.30	UPTO 80.0mm - ±0.70	UPTO 180.0mm - ±1.27	1. STRAIGHTNESS=1.7mm/M 2. TWIST=1.7mm/M 3. ANGULARITY= ±2° 4. FLATNESS =0.006xWIDTH
UPTO 30.0mm - ±0.38	UPTO 100.0mm - ±0.80	UPTO 200.0mm - ±1.40	
UPTO 40.0mm - ±0.45	UPTO 120.0mm - ±0.90	UPTO 225.0mm - ±1.52	
UPTO 50.0mm - ±0.52	UPTO 140.0mm - ±1.00		
UPTO 60.0mm - ±0.60	UPTO 160.0mm - ±1.14		

 SYMBOL OF QUALITY AN ISO 9001 COMPANY	<b>JINDAL ALUMINIUM LTD.</b> BANGALORE-560073 (INDIA)	NAME	DATE
		DRAWN	J.P.KAUSHIK
		CHECKED	
		APPROVED	J.N.RAI
			03-09-2020
1. ALL DIMENSIONS ARE IN mm. 2. ROUND OFF ALL SHARP CORNERS WITH 0.40 mm. 3. TOLERANCES WILL BE AS PER IS:3965-1981 UNLESS OTHERWISE SPECIFIED		SCALE	2:1
		AREA mm <sup>2</sup>	187.779
		PERIMETER mm.	149.246
PARTY'S NAME	KRUEGER INTERNATIONAL FURNITURE SYSTEMS PVT. LTD., BANGALORE	WEIGHT kg/m	0.507
PARTY'S DRAWING No.	AS PER SAMPLE	DRAWING No.	SECTION No.
ALLOY & TEMPER	HE9 WP	P-20527	-
DESCRIPTION	MISC. SECTION	E1368	E1368