

P-20318

S6533

E1388

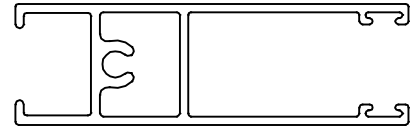

SCALE: - 1:1

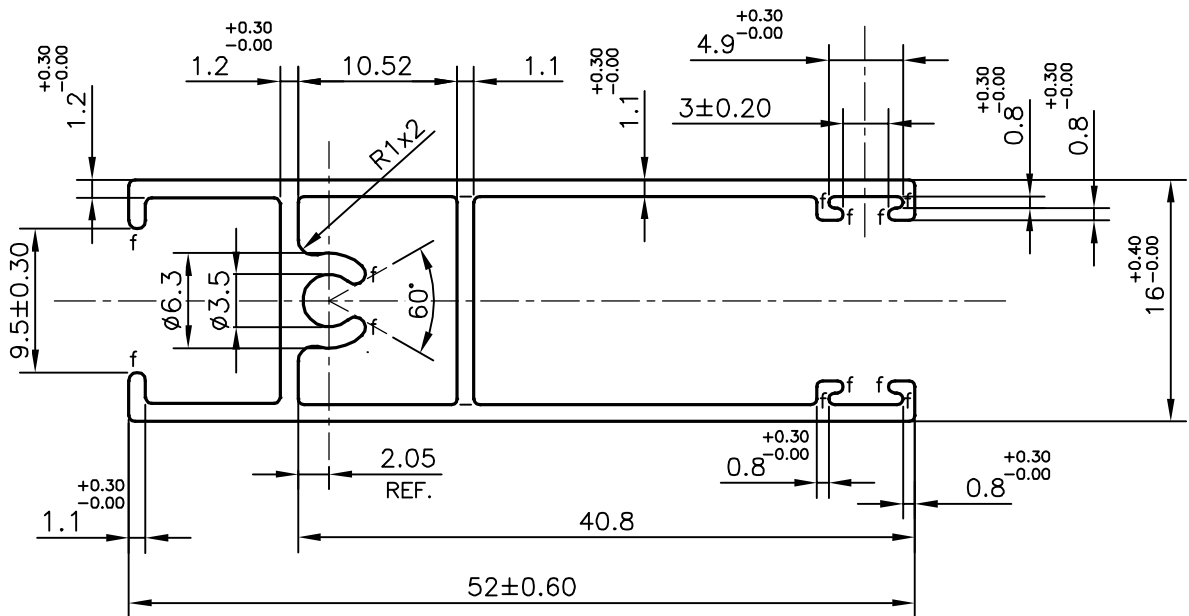

f=FULL RADIUS (12 PLACES)

TOLERANCES ON OVERALL DIMENSIONS OF HOLLOW SECTIONS

UPTO 20.0mm - ±0.30	UPTO 80.0mm - ±0.70	UPTO 180.0mm - ±1.27	1. STRAIGHTNESS=1.7mm/M 2. TWIST=1.7mm/M 3. ANGULARITY= ±2° 4. FLATNESS =0.006xWIDTH
UPTO 30.0mm - ±0.38	UPTO 100.0mm - ±0.80	UPTO 200.0mm - ±1.40	
UPTO 40.0mm - ±0.45	UPTO 120.0mm - ±0.90	UPTO 225.0mm - ±1.52	
UPTO 50.0mm - ±0.52	UPTO 140.0mm - ±1.00		
UPTO 60.0mm - ±0.60	UPTO 160.0mm - ±1.14		



SYMBOL OF QUALITY
AN ISO 9001 COMPANY

JINDAL ALUMINIUM LTD.
BANGALORE-560073 (INDIA)

	NAME	DATE
DRAWN	DARPAN	24-10-2019
CHECKED		
APPROVED	B.NATARAJA	04-11-2019

1. ALL DIMENSIONS ARE IN mm.
2. ROUND OFF ALL SHARP CORNERS WITH 0.40 mm.
3. TOLERANCES WILL BE AS PER IS:6477-1983, UNLESS OTHERWISE SPECIFIED

SCALE	2:1
AREA mm ²	175.57
PERIMETER mm.	236.522
WEIGHT kg/m	0.474

PARTY'S NAME PARAMOUNT INDUSTRIES., BANGALORE.

PARTY'S DRAWING No. P-AL8764-30L

ALLOY & TEMPER 6063 T6

DESCRIPTION WINDOW SECTION

DRAWING No.	SECTION No.
P-20318	-
S6533	S6533
E1388	E1388