

P-21353-2

E1391

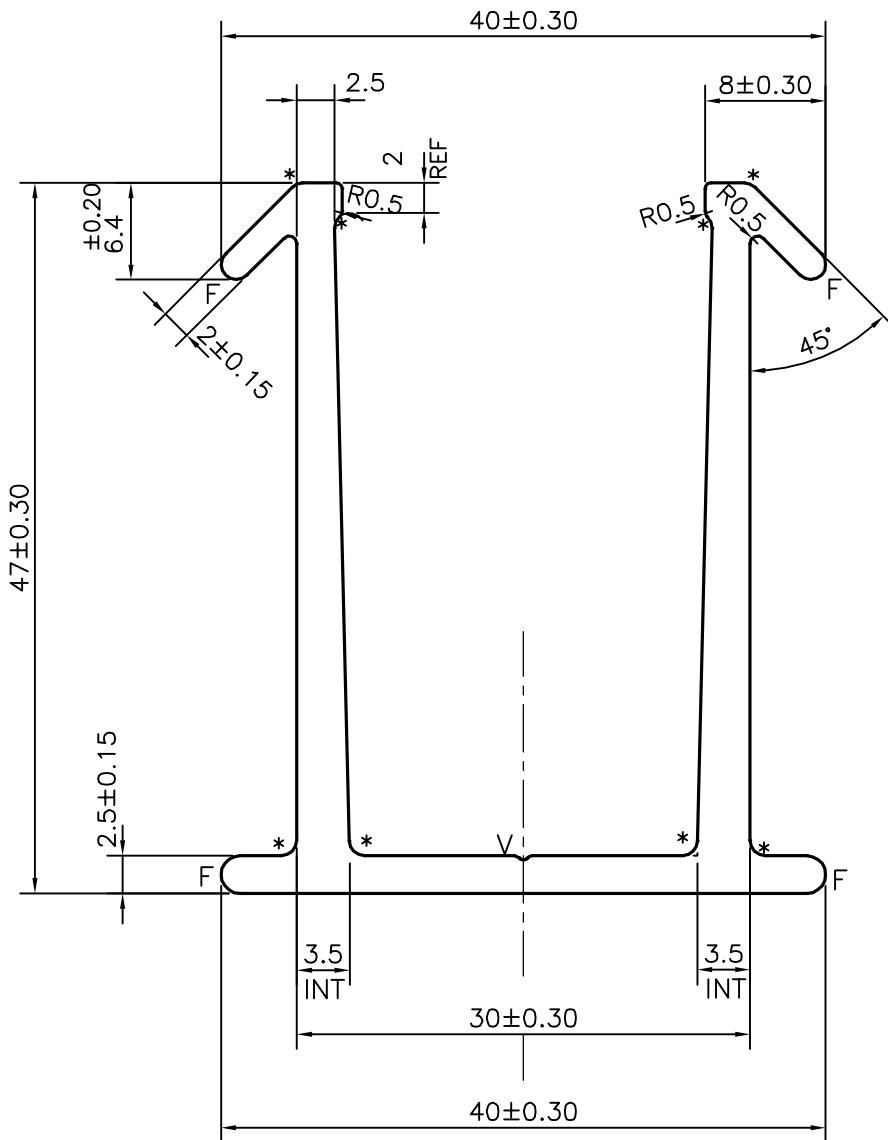

SCALE: - 2:1

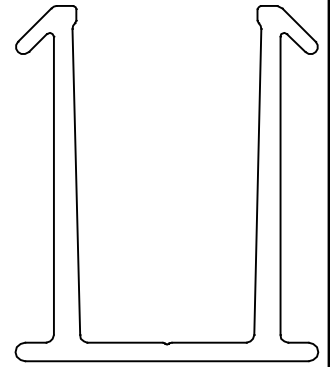

SCALE: - 1:1

- \* = 1.0 RADIUS (8 PLACES)
- F = FULL RADIUS (4 PLACES)
- V = V GROOVE 0.3x90° (1 PLACE)



SYMBOL OF QUALITY  
AN ISO 9001 COMPANY

**JINDAL ALUMINIUM LTD.**  
BANGALORE-560073 (INDIA)

	NAME	DATE
DRAWN	J.P.KAUSHIK	26-09-2020
CHECKED		
APPROVED	B.NATARAJA	03-10-2020
SCALE		2:1
AREA mm <sup>2</sup>		391.958
PERIMETER mm.		279.052
WEIGHT kg/m		1.058
DRAWING No.	SECTION No.	
P-21353-2	-	
E1391	E1391	

1. ALL DIMENSIONS ARE IN mm.
2. ROUND OFF ALL SHARP CORNERS WITH 0.40 mm.
3. TOLERANCES WILL BE AS PER IS:3965-1981 , UNLESS OTHERWISE SPECIFIED

PARTY'S NAME	SWIKRITI RENEWABLES PVT. LTD., MUMBAI
PARTY'S DRAWING No.	401071 REV. 02
ALLOY & TEMPER	6063 T6
DESCRIPTION	RAIL LANDSCAPE-47 mm SECTION