

P-21355-2

E1393

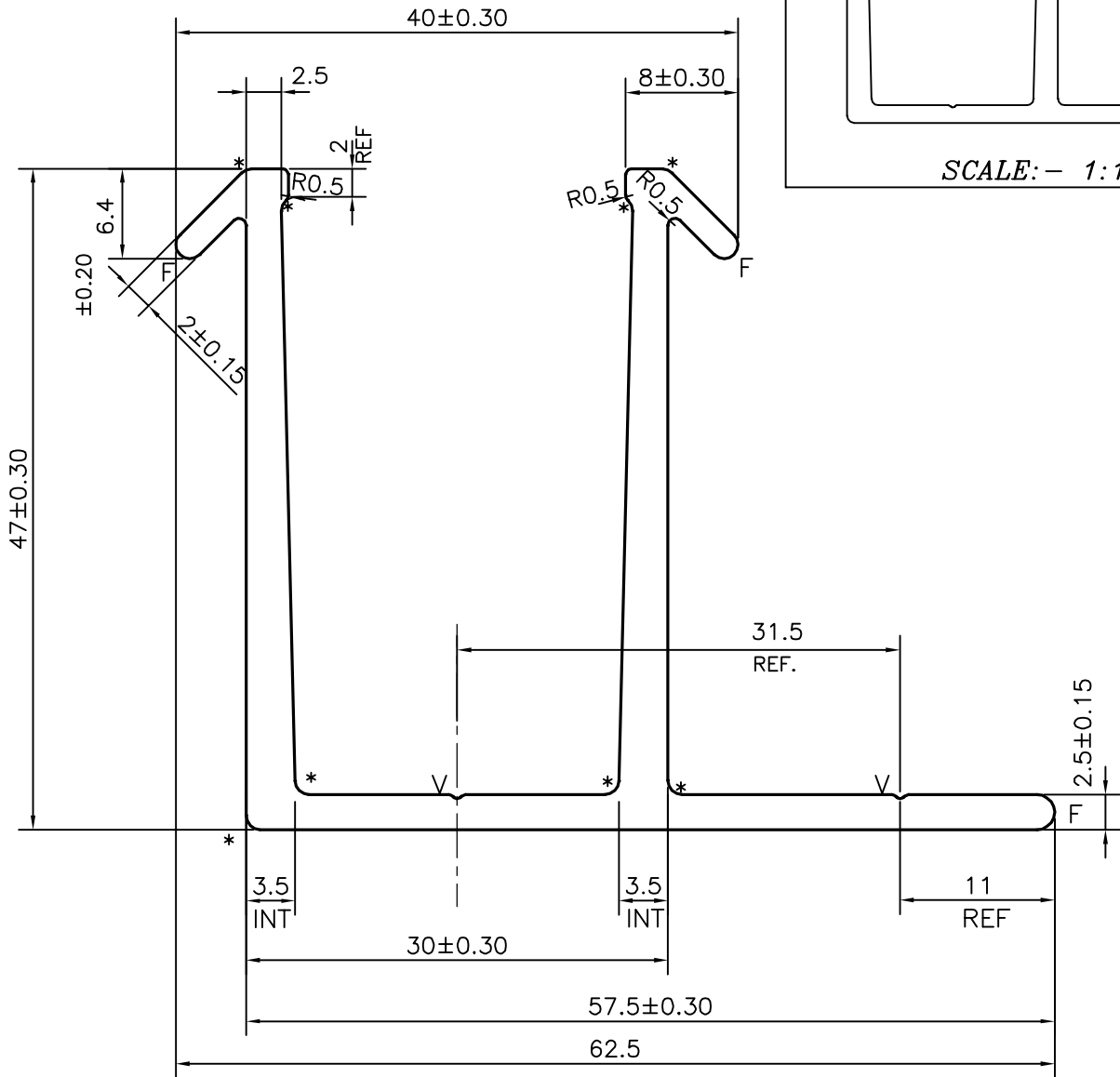

SCALE: - 2:1

- * = 1.0 RADIUS (8 PLACES)
- F = FULL RADIUS (4 PLACES)
- V = V GROOVE 0.3x90° (2 PLACES)



SYMBOL OF QUALITY
AN ISO 9001 COMPANY

JINDAL ALUMINIUM LTD.
BANGALORE-560073 (INDIA)

	NAME	DATE
DRAWN	J.P.KAUSHIK	26-09-2020
CHECKED		
APPROVED	B.NATARAJA	03-10-2020

1. ALL DIMENSIONS ARE IN mm.
2. ROUND OFF ALL SHARP CORNERS WITH 0.40 mm.
3. TOLERANCES WILL BE AS PER IS:3965-1981 , UNLESS OTHERWISE SPECIFIED

SCALE	2:1
AREA mm ²	435.782
PERIMETER mm.	315.314
WEIGHT kg/m	1.177

PARTY'S NAME	SWIKRITI RENEWABLES PVT. LTD., MUMBAI	DRAWING No.	P-21355-2	SECTION No.	-
PARTY'S DRAWING No.	401058 REV. 03		E1393		E1393
ALLOY & TEMPER	6063 T6				
DESCRIPTION	RAIL PORTRAIT-47 mm SECTION				