

P-21357-2

E1395

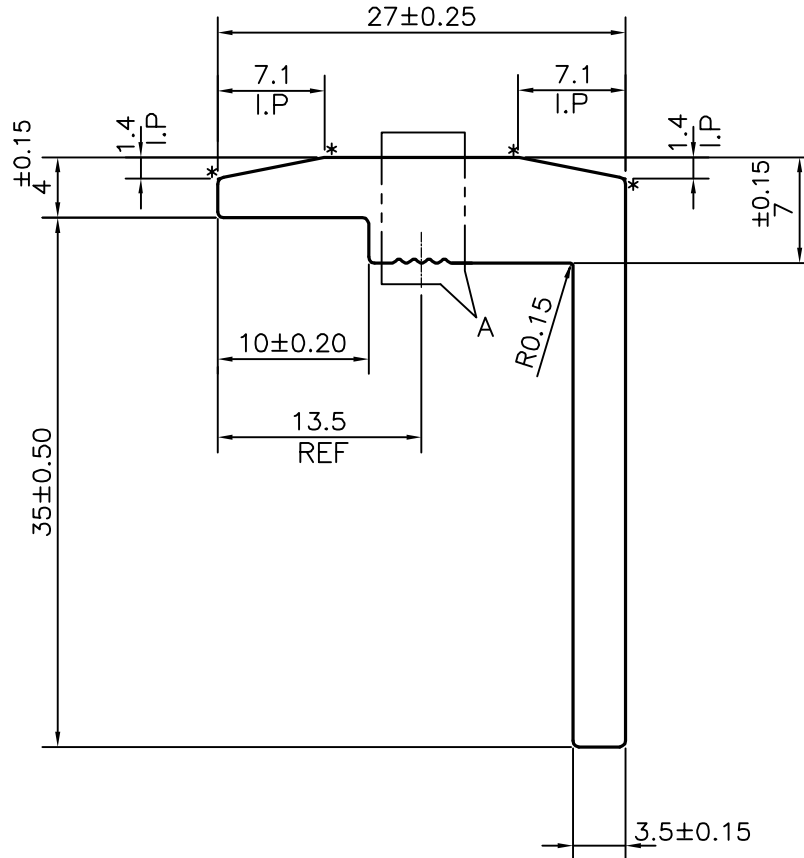

* = 0.50 RADIUS (4 PLACES)

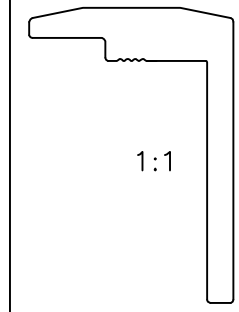
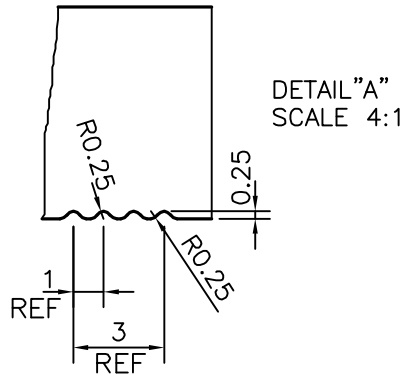

SYMBOL OF QUALITY
AN ISO 9001 COMPANY

JINDAL ALUMINIUM LTD.
BANGALORE-560073 (INDIA)

	NAME	DATE
DRAWN	J.P.KAUSHIK	26-09-2020
CHECKED		
APPROVED	B.NATARAJA	03-10-2020
SCALE		2:1
AREA mm ²		260.462
PERIMETER mm.		130.324
WEIGHT kg/m		0.703
DRAWING No.	SECTION No.	
P-21357-2	-	
E1395	E1395	

1. ALL DIMENSIONS ARE IN mm.
2. ROUND OFF ALL SHARP CORNERS WITH 0.40 mm.
3. TOLERANCES WILL BE AS PER IS:3965-1981 , UNLESS OTHERWISE SPECIFIED

PARTY'S NAME	SWIKRITI RENEWABLES PVT. LTD., MUMBAI
PARTY'S DRAWING No.	401097-02 REV. 01
ALLOY & TEMPER	6063 T6
DESCRIPTION	END CLAMP-35 mm SECTION