

P-21601-1

E1411

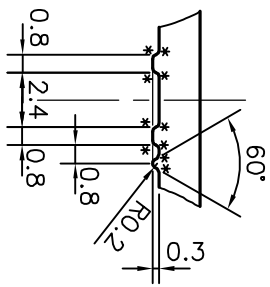

DETAIL "C"
SCALE 3:1

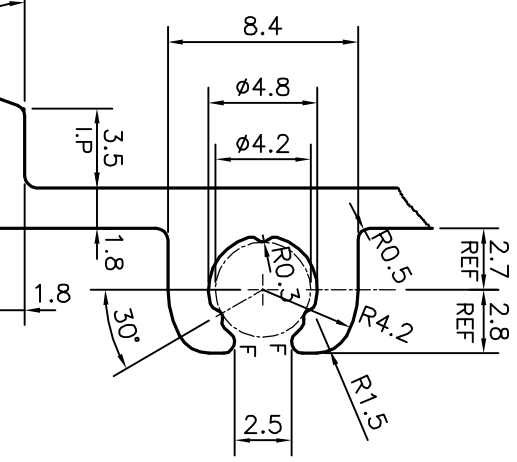
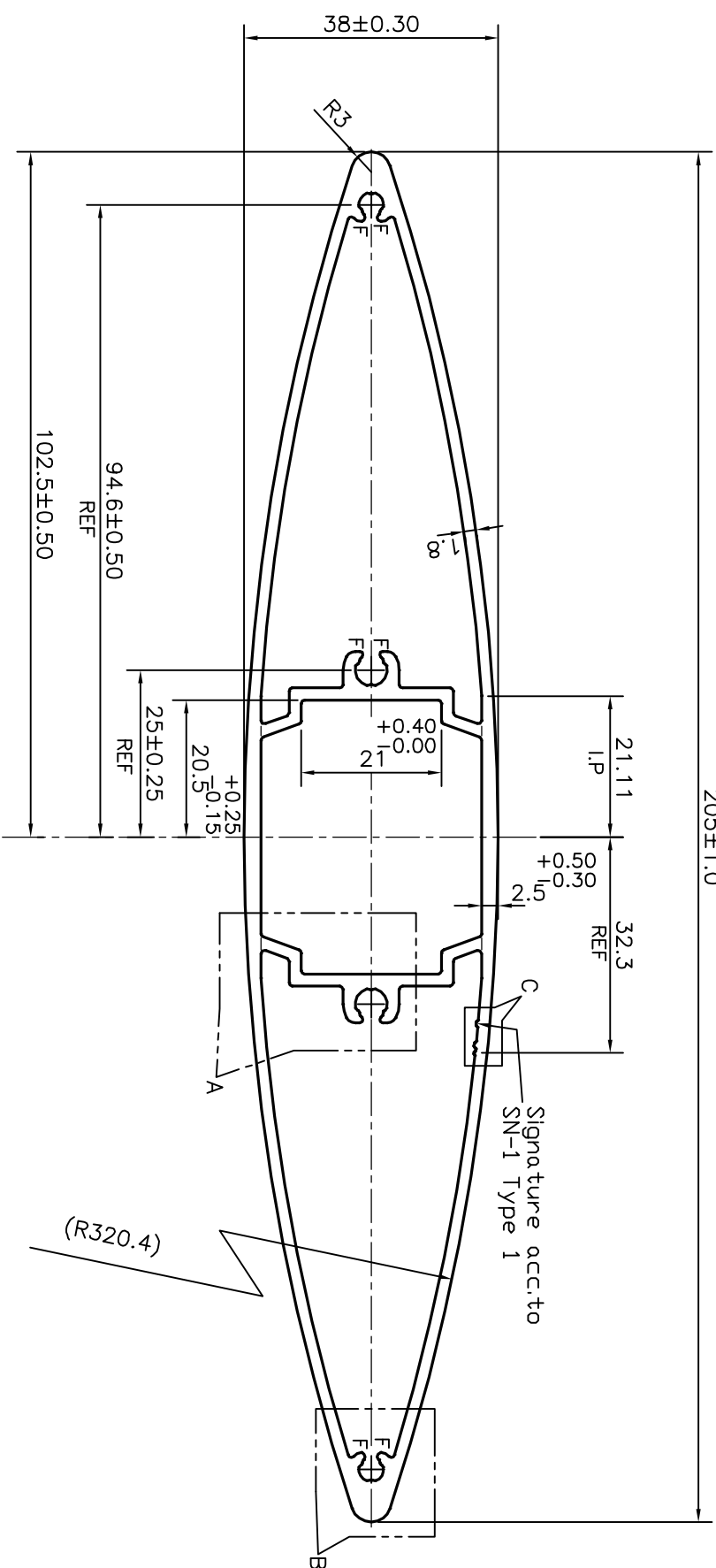

DETAIL OF A
SCALE 3:1

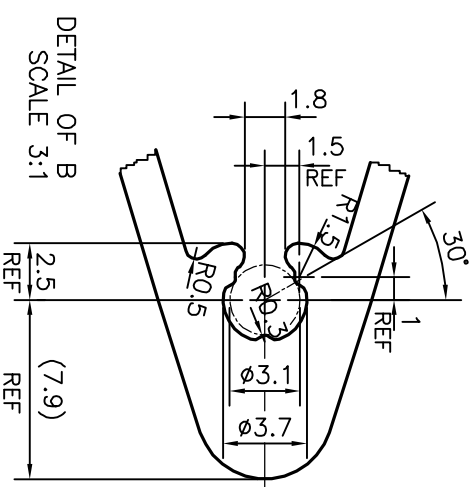

DETAIL OF B
SCALE 3:1

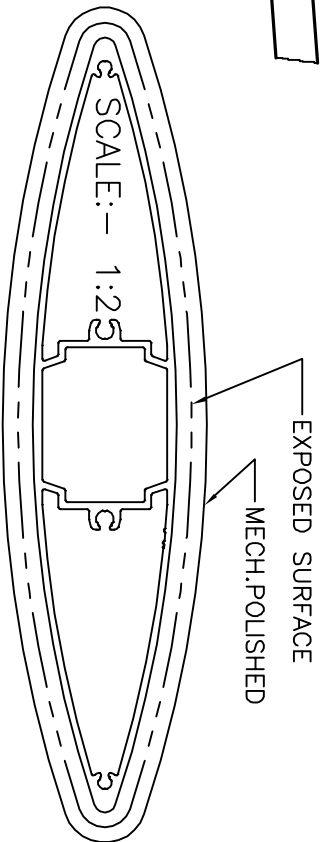

F = FULL RADIUS (8 PLACES)

PLEASE CONFIRM ALL THE DIMENSIONS AND MATCH WITH YOUR MATCHING COMPONENT PLEASE SPECIFY THE EXPOSED SURFACE IN THE DRAWING WHEREVER BETTER FINISH REQUIRED.			
DIMENSION	UP TO AND INCLUDING	TOLERANCES (EXCEPT OPEN ENDS)	TOLERANCES (OPEN ENDS)
OVER	10	±0.15	60<E≤120
10	15	±0.20	
15	30	±0.25	
30	45	±0.30	±0.45
45	60	±0.40	±0.55
60	90	±0.45	±0.65
90	120	±0.60	±0.80
120	150	±0.80	±1.0
150	180	±1.0	±1.2
180	240	±1.2	±1.5
240	300	±1.5	±1.8

<p>SYMBOL OF QUALITY AN ISO 9001 COMPANY</p>		<p>JINDAL ALUMINIUM LTD. BANGALORE-560073 (INDIA)</p>	
<p>1. ALL DIMENSIONS ARE IN mm. 2. ROUND OFF ALL SHARP CORNERS WITH 0.50 mm. 3. TOLERANCES WILL BE AS PER BS:EN-12020-2 UNLESS OTHERWISE SPECIFIED</p>			
PARTY'S NAME	SCHUECO INDIA PVT. LTD., BANGALORE	DRAWN	J.P. KAUSHIK 29-09-2020
PARTY'S DRAWING No.	327710_FZ_0000	CHECKED	
ALLOY & TEMPER	6060 T66	APPROVED	B.NATARAJA 10-10-2020
DESCRIPTION	LOUVER SECTION	SCALE	1:1
		AREA mm ²	1042.309
		PERIMETER mm.	423.675
		WEIGHT kg/m	2.814
		DRAWING No.	P-21601-1
		SECTION No.	-
			E1411
			E1411