

P-21374-1

E1415

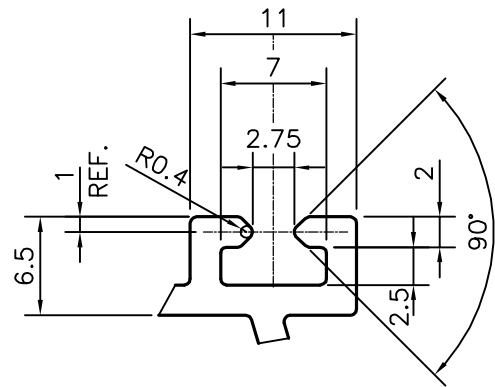

DETAIL OF "A"
SCALE 2:1

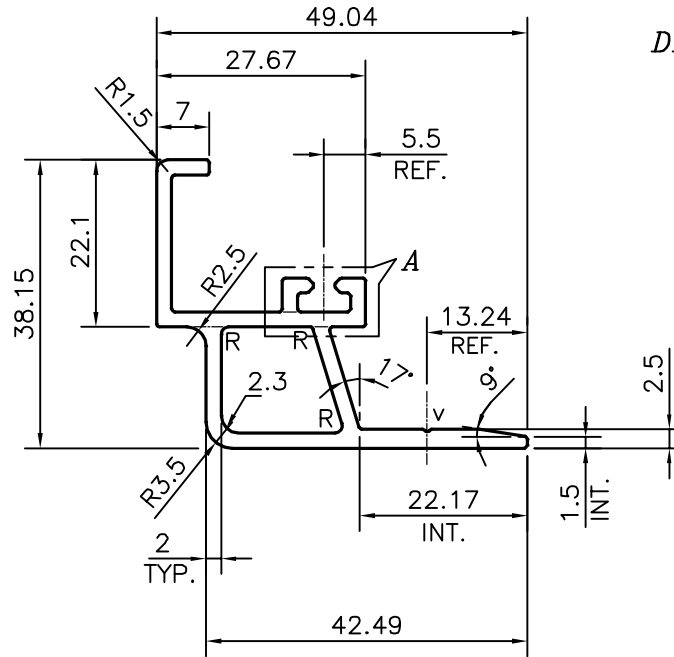

R=1.0 RADIUS (3 PLACES)
V= V GROOVE 0.3x90° (1 PLACE)

TOLERANCES ON OVERALL DIMENSIONS OF HOLLOW SECTIONS

UPTO 20.0mm - ±0.30	UPTO 80.0mm - ±0.70	UPTO 180.0mm - ±1.27	1. STRAIGHTNESS=1.7mm/M 2. TWIST=1.7mm/M 3. ANGULARITY= ±2° 4. FLATNESS =0.006xWIDTH
UPTO 30.0mm - ±0.38	UPTO 100.0mm - ±0.80	UPTO 200.0mm - ±1.40	
UPTO 40.0mm - ±0.45	UPTO 120.0mm - ±0.90	UPTO 225.0mm - ±1.52	
UPTO 50.0mm - ±0.52	UPTO 140.0mm - ±1.00		
UPTO 60.0mm - ±0.60	UPTO 160.0mm - ±1.14		



SYMBOL OF QUALITY
AN ISO 9001 COMPANY

JINDAL ALUMINIUM LTD.
BANGALORE-560073 (INDIA)

	NAME	DATE
DRAWN	J.P.KAUSHIK	03-09-2020
CHECKED		
APPROVED	B.NATARAJA	17-10-2020
SCALE		1:1
AREA mm ²		280.88
PERIMETER mm.		208.259
WEIGHT kg/m		0.758
DRAWING No.		SECTION No.
P-21374-1		-
E1415		E1415

1. ALL DIMENSIONS ARE IN mm.
2. ROUND OFF ALL SHARP CORNERS WITH 0.40 mm.
3. TOLERANCES WILL BE AS PER IS:6477-1983 , UNLESS OTHERWISE SPECIFIED

PARTY'S NAME	NEW ERA INDUSTRIES, NEW DELHI
PARTY'S DRAWING No.	NEI-1003 & REQUIREMENT
ALLOY & TEMPER	6063 T6
DESCRIPTION	CLAMP SECTION-BOTTOM