

P-21736-3

E1437

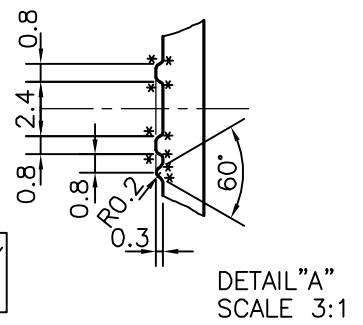
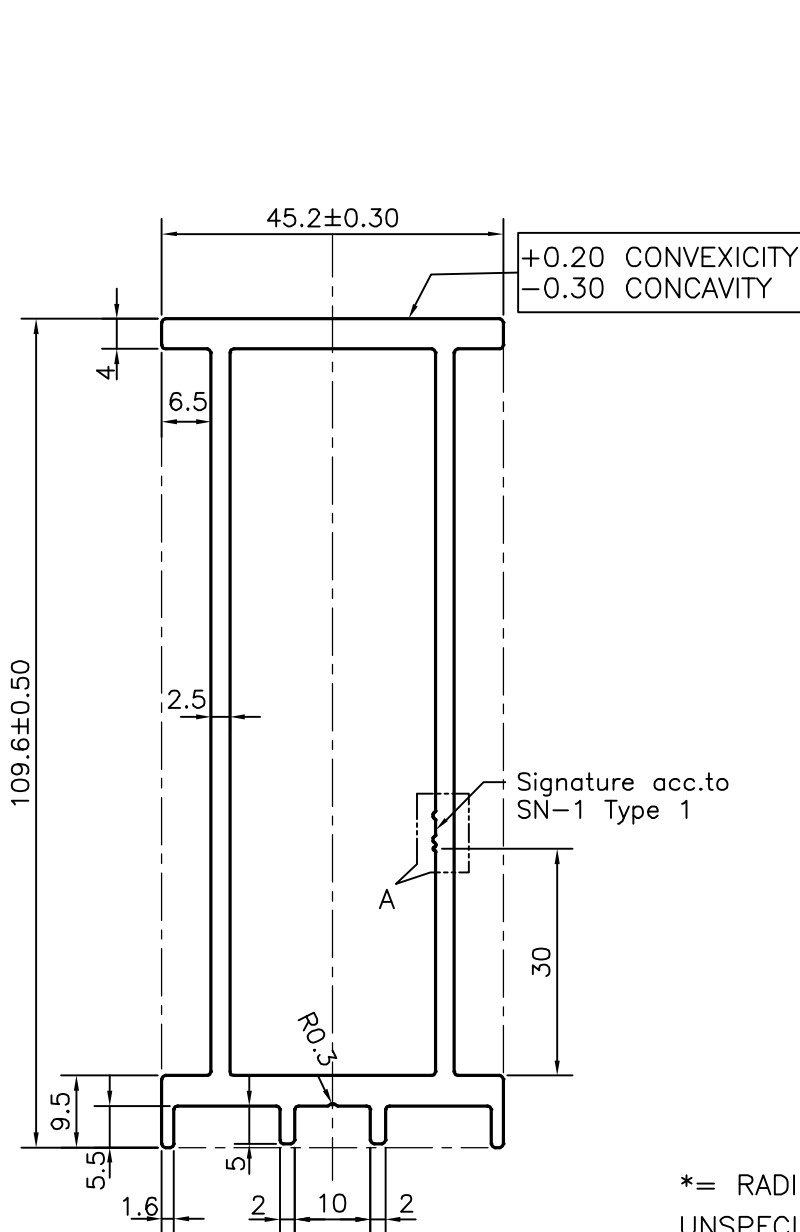

\*= RADIUS 0.20 (10 PLACES)  
UNSPECIFIED RADIUS 0.50 mm

DIMENSION		TOLERANCES (EXCEPT OPEN ENDS)	TOLERANCES (OPEN ENDS)	
OVER	UP TO AND INCLUDING		E ≤ 60	60 < E ≤ 120 <sup>d</sup>
-	10	±0.15	±0.15	-
10	15	±0.20	±0.20	-
15	30	±0.25	±0.25	-
30	45	±0.30	±0.30	±0.45
45	60	±0.40	±0.40	±0.55
60	90	±0.45	±0.45	±0.65
90	120	±0.60	±0.60	±0.80
120	150	±0.80	±0.80	±1.0
150	180	±1.0	±1.0	±1.3
180	240	±1.2	±1.2	±1.5
240	300	±1.5	±1.5	±1.8



SYMBOL OF QUALITY  
AN ISO 9001 COMPANY

**JINDAL ALUMINIUM LTD.**  
BANGALORE-560073 (INDIA)

	NAME	DATE
DRAWN	J.P.KAUSHIK	19-11-2020
CHECKED		
APPROVED	B.NATARAJA	05-12-2020

- ALL DIMENSIONS ARE IN mm.
- ROUND OFF ALL SHARP CORNERS WITH 0.50 mm.
- TOLERANCES WILL BE AS PER BS:EN-12020-2 , UNLESS OTHERWISE SPECIFIED

SCALE	1:1
AREA mm <sup>2</sup>	880.125
PERIMETER mm.	361.634
WEIGHT kg/m	2.376

PARTY'S NAME	SCHUECO INDIA PVT. LTD., BANGALORE
PARTY'S DRAWING No.	440500_FZ_0000
ALLOY & TEMPER	6060 T66
DESCRIPTION	MULLION INSERT SECTION

DRAWING No.	SECTION No.
P-21736-3	-
E1437	E1437