

P-21769-1  
E1438

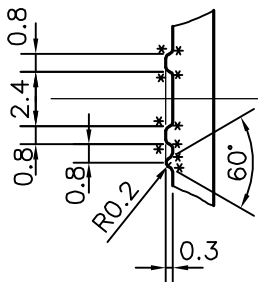

DETAIL "B"  
SCALE 3:1

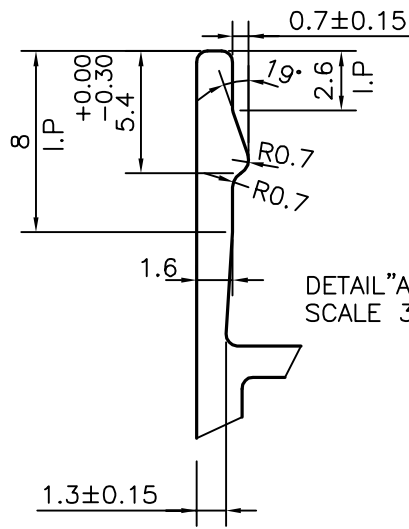

DETAIL "A"  
SCALE 3:1

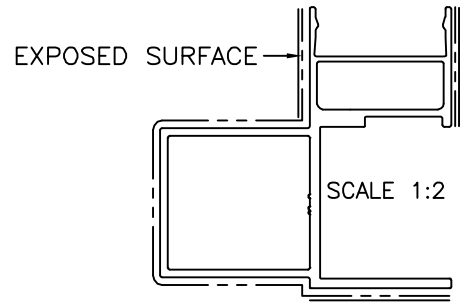

SCALE 1:2

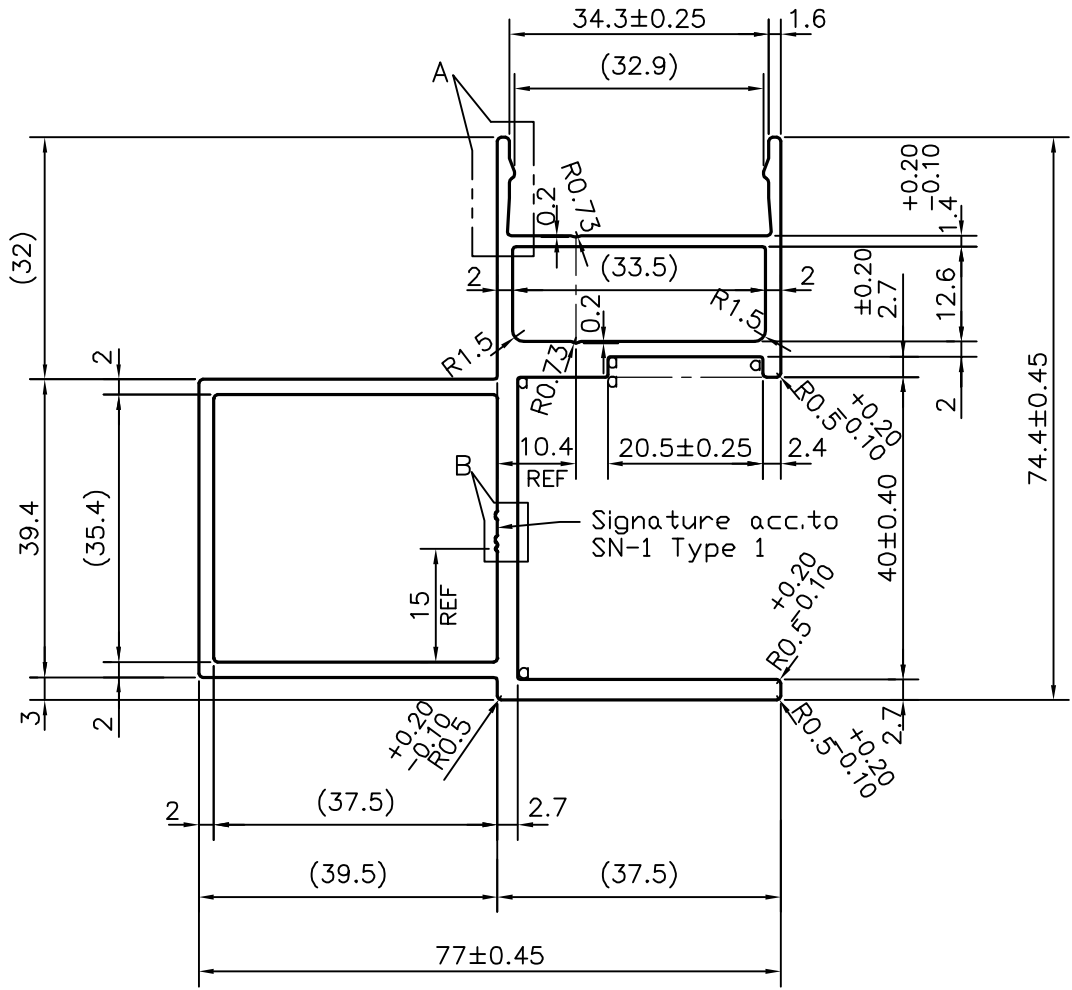

a = RADIUS 0.30 (5 PLACES)  
\* = RADIUS 0.20 (10 PLACES)  
UNSPECIFIED RADIUS 0.50 mm

 SYMBOL OF QUALITY AN ISO 9001 COMPANY	<b>JINDAL ALUMINIUM LTD.</b> BANGALORE-560073 (INDIA)	NAME	DATE
		DRAWN	J.P.KAUSHIK
		CHECKED	
		APPROVED	B.NATARAJA
		SCALE	1:1
		AREA mm <sup>2</sup>	705.507
		PERIMETER mm.	401.369
		WEIGHT kg/m	1.905
PARTY'S NAME	SCHUECO INDIA PVT. LTD., BANGALORE	DRAWING No.	SECTION No.
PARTY'S DRAWING No.	9074509_FZ_0000	P-21769-1	-
ALLOY & TEMPER	6060 T66	E1438	E1438
DESCRIPTION	VENT FRAME SECTION		