

P-22787-1

E1628

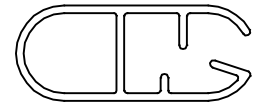

SCALE:- 1:1

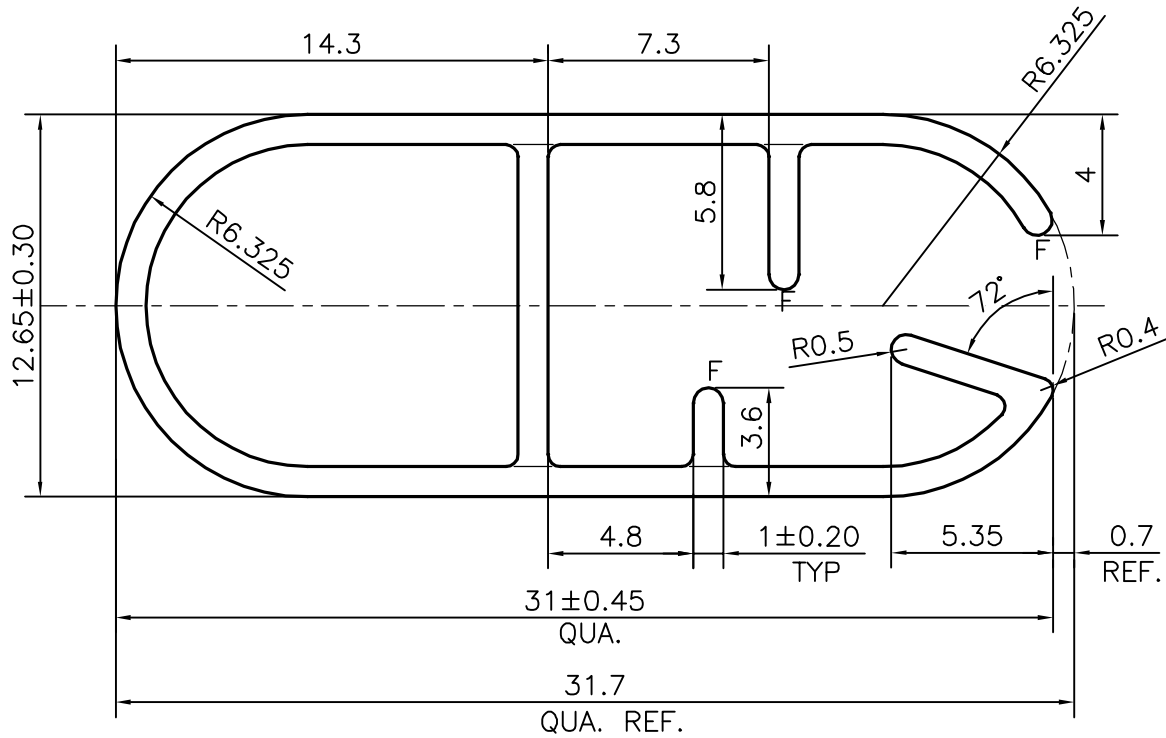

SCALE 4:1

F = FULL RADIUS (3 PLACES)

APPROXIMATE WEIGHT RANGE - 0.199 - 0.299 kg/m

TOLERANCES ON OVERALL DIMENSIONS OF HOLLOW SECTIONS

UPTO 20.0mm - ±0.30	UPTO 80.0mm - ±0.70	UPTO 180.0mm - ±1.27	1. STRAIGHTNESS=1.7mm/M 2. TWIST=1.7mm/M 3. ANGULARITY= ±2° 4. FLATNESS =0.006xWIDTH
UPTO 30.0mm - ±0.38	UPTO 100.0mm - ±0.80	UPTO 200.0mm - ±1.40	
UPTO 40.0mm - ±0.45	UPTO 120.0mm - ±0.90	UPTO 225.0mm - ±1.52	
UPTO 50.0mm - ±0.52	UPTO 140.0mm - ±1.00		
UPTO 60.0mm - ±0.60	UPTO 160.0mm - ±1.14		



SYMBOL OF QUALITY
AN ISO 9001 COMPANY

JINDAL ALUMINIUM LTD.
BANGALORE-560073 (INDIA)

- ALL DIMENSIONS ARE IN mm.
- ROUND OFF ALL SHARP CORNERS WITH 0.40 mm.
- TOLERANCES WILL BE AS PER IS:6477-1983, UNLESS OTHERWISE SPECIFIED

PARTY'S NAME	MAC LIFESTYLE PRODUCT LTD., NEW DELHI	DRAWN	NAME	DATE
		CHECKED	SONU	06-08-2021
PARTY'S DRAWING No.	AS PER DRAWING & REQUIREMENT	APPROVED	B.NATARAJA	25-09-2021
		SCALE		4:1
ALLOY & TEMPER	6063 T6	AREA	mm ²	92.212
		PERIMETER	mm.	139.909
DESCRIPTION	VENETIAN BLIND SECTION	WEIGHT	kg/m	0.249
		DRAWING No.		SECTION No.
		P-22787-1		
		E1628		E1628