

P-22733-2

E1647

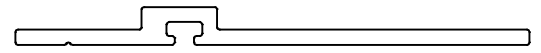

SCALE 1:1

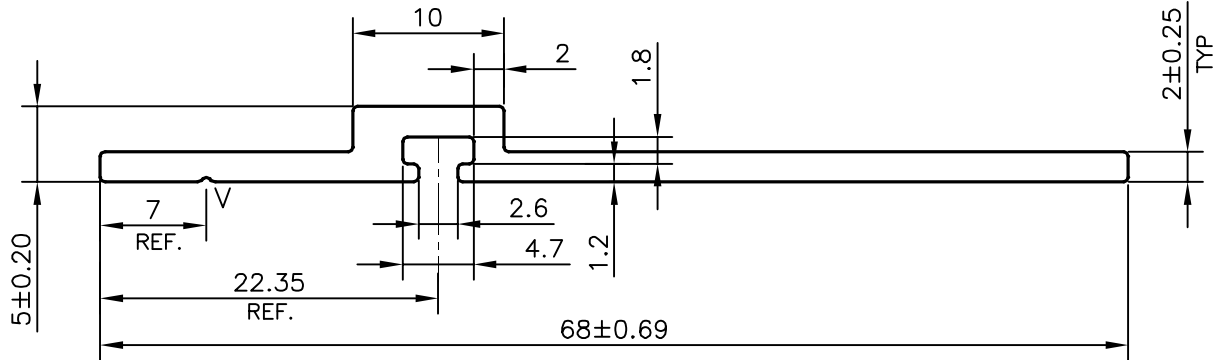

SCALE: - 2:1

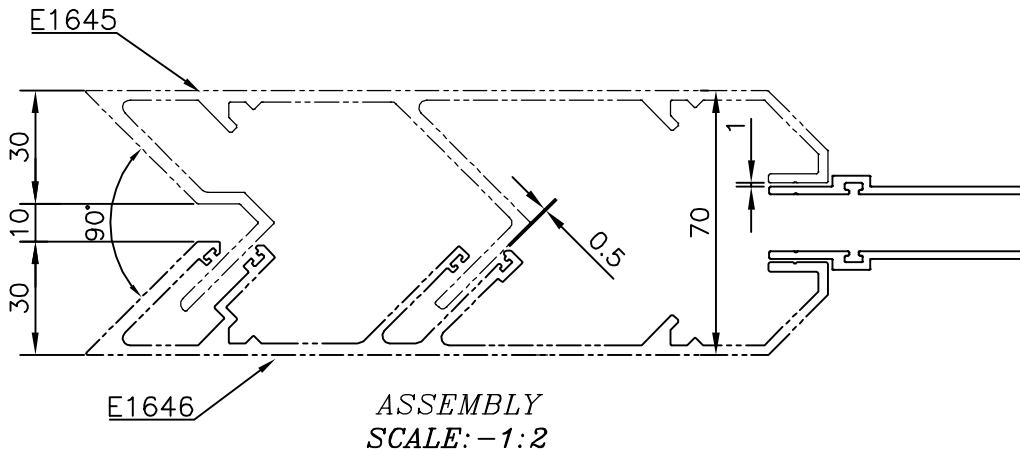

ASSEMBLY  
SCALE: - 1:2

**FINISH:- POWDER COATING**

V = V GROOVE 0.3x90° (1 PLACE)

**APPROXIMATE WEIGHT RANGE - 0.364 - 0.468 kg/m**

TOLERANCES ON OVERALL WIDTHS & WIDTHS ACROSS FLATS OF BARS, & REGULAR SECTIONS

|                     |                      |                      |   |
|---------------------|----------------------|----------------------|---|
| UPTO 6.40mm - ±0.20 | UPTO 32.0mm - ±0.38  | UPTO 120.0mm - ±0.85 | 1. STRAIGHTNESS= 1.0mm/M<br>2. TWIST= 1.0mm/M<br>3. ANGULARITY= ±1°<br>4. FLATNESS =0.007xWIDTH |
| UPTO 10.0mm - ±0.23 | UPTO 50.0mm - ±0.46  | UPTO 160.0mm - ±1.02 |   |
| UPTO 12.0mm - ±0.25 | UPTO 60.0mm - ±0.53  | UPTO 200.0mm - ±1.14 |   |
| UPTO 16.0mm - ±0.28 | UPTO 80.0mm - ±0.69  | UPTO 250.0mm - ±1.40 |   |
| UPTO 25.0mm - ±0.30 | UPTO 100.0mm - ±0.75 | UPTO 300.0mm - ±1.65 |   |



SYMBOL OF QUALITY  
AN ISO 9001 COMPANY

**JINDAL ALUMINIUM LTD.**  
BANGALORE-560073 (INDIA)

|          |            |            |
|----------|------------|------------|
|          | NAME       | DATE       |
| DRAWN    | SONU       | 21-09-2021 |
| CHECKED  |            |            |
| APPROVED | B.NATARAJA | 01-10-2021 |

1. ALL DIMENSIONS ARE IN mm.
2. ROUND OFF ALL SHARP CORNERS WITH 0.30 mm.
3. TOLERANCES WILL BE AS PER IS:3965-1981 , UNLESS OTHERWISE SPECIFIED

|                      |         |
|----------------------|---------|
| SCALE                | 2:1     |
| AREA mm <sup>2</sup> | 154.175 |
| PERIMETER mm.        | 154.328 |
| WEIGHT kg/m          | 0.416   |

|                     |                                     |
|---------------------|-------------------------------------|
| PARTY'S NAME        | ALUFIT (INDIA) PVT. LTD., BANGALORE |
| PARTY'S DRAWING No. | HP-DIE-19 & REQUIREMENT             |
| ALLOY & TEMPER      | 6063 T6                             |
| DESCRIPTION         | CURTAIN WALL - EDGE GUARD SECTION   |

|             |             |
|-------------|-------------|
| DRAWING No. | SECTION No. |
| P-22733-2   | -           |
| E1647       | E1647       |