

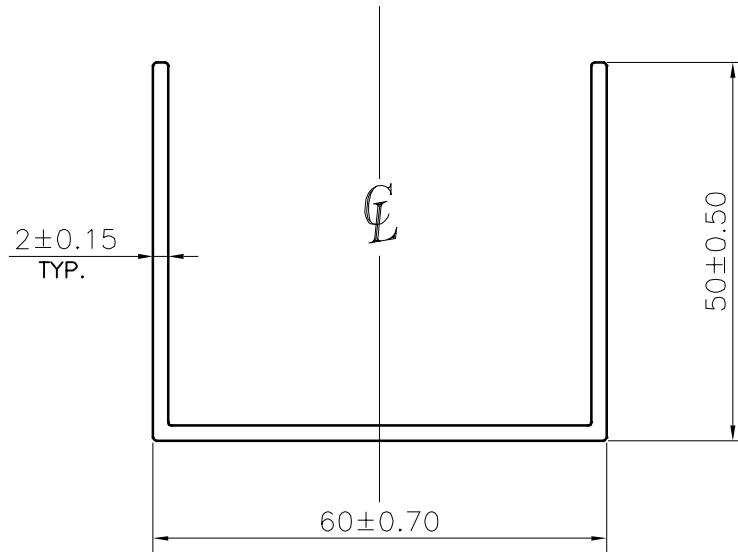

P-24914

G100685



control led copy

 SYMBOL OF QUALITY AN ISO 9001 COMPANY	JINDAL ALUMINIUM LTD. BANGALORE-560073 (INDIA)	DRAWN	NAME	DATE
		CHECKED	ADITYA N	01-02-2023
1. ALL DIMENSIONS ARE IN mm. 2. ROUND OFF ALL SHARP CORNERS WITH 0.40 mm. 3. TOLERANCES WILL BE AS PER BS:EN-755-9 , UNLESS OTHERWISE SPECIFIED		APPROVED	B.NATARAJA	07-02-2023
		SCALE		1:1
PARTY'S NAME IMS NEDERLAND B.V., NETHERLANDS		AREA	mm ²	311.863
		PERIMETER	mm.	314.627
PARTY'S DRAWING No. AS PER SPECIFICATION		WEIGHT	kg/m	0.842
		DRAWING No.		SECTION No.
ALLOY & TEMPER 6060 T66		P-24914		70000094
		G100685		G100685
DESCRIPTION U-SECTION (CHANNEL SECTION)		PRODUCT CODE:-014		
		HSN CODE:-76042990		